



Roto DUO



Multipunto



GRUPOM22
ALUMINIOS & HERRAJES

CALADO CIERRE DUO





C) RO FRA S.A. THE REGISTRATION, PATENTING AND PROTECTION OF THE
 TRADEMARKS, AS WELL AS THE COMMUNICATION OF ITS CONTENTS TO OTHERS
 THESE RIGHTS ARE RESERVED. ANY REPRODUCTION OR USE OF THESE RIGHTS WITHOUT THE
 WRITTEN PERMISSION OF RO FRA S.A. IS PROHIBITED. BUENOS AIRES, ARGENTINA.

E1.8/main /		Scale		Calado DUO	
Rev. No.	04-2-09	Scale	1:1		
Effect Key	N	Revision	Andres SAMSA	DUO	
Replaces	-	ROTO FRANK S.A.		BUENOS AIRES	
				Sheet No. 1 of 1	
				Rev. No. E1	

Modena 90 y 45

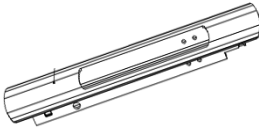
SISTEMA: ROTO DUO

CODIGO	DESCRIPCION	
FECDUOA005	CIERRE DUO NEGRO R06.2	
FECDUOP021	CIERRE DUO BLANCO R07.2	
387095	CIERRE DUO PLATA	
335555	TOPE CORREDERA NEGRO (ALU)	
317250	TOPE CORREDERA BLANCO (ALU)	

KIT MODENA 45°		
391852	GANCHO DUO H002 (Perimetral Recto)	
392027	CERRADERO DUO K001	

KIT MODENA 90°		
391851	GANCHO DUO H001	
391851C	CERRADERO DUO (No perimetral)	

446595 PLANTILLA PARA CIERRE DUO



VENTANA Y PUERTA CORREDIZA MODENA A 45° y MODENA 90°

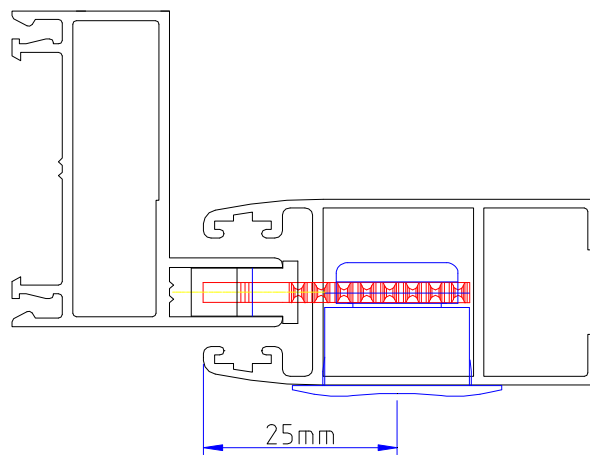
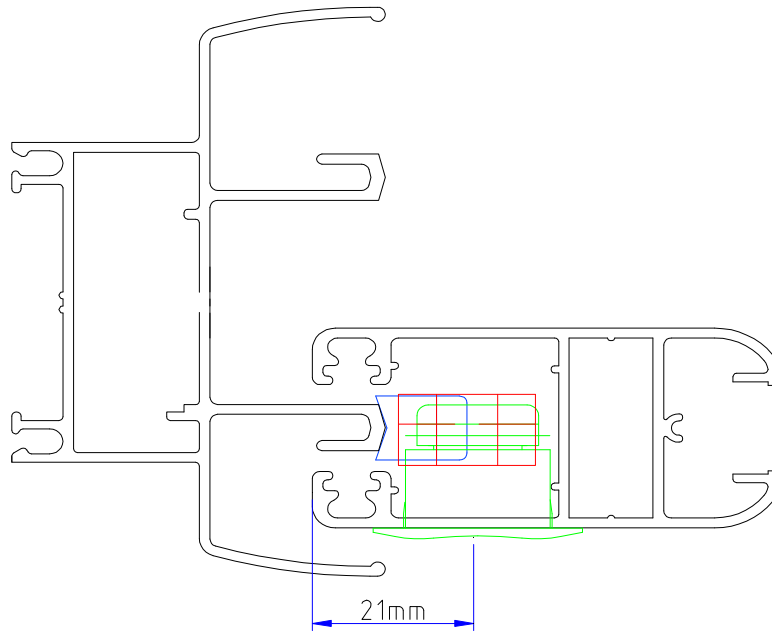

E18/main / Entwicklung	-		-	Scale	Perfiles: Aluar-
	-		-	1:1	
	1		AB	-	
	Qty.	Date	Name	Revision	
Issue No.	-	Replaces	-		Duo
Effect Key	N				Sheet No. 1 of 1

GRAFICO
D3

**CALADO SISTEMA DUO
EN MODENA 45°**

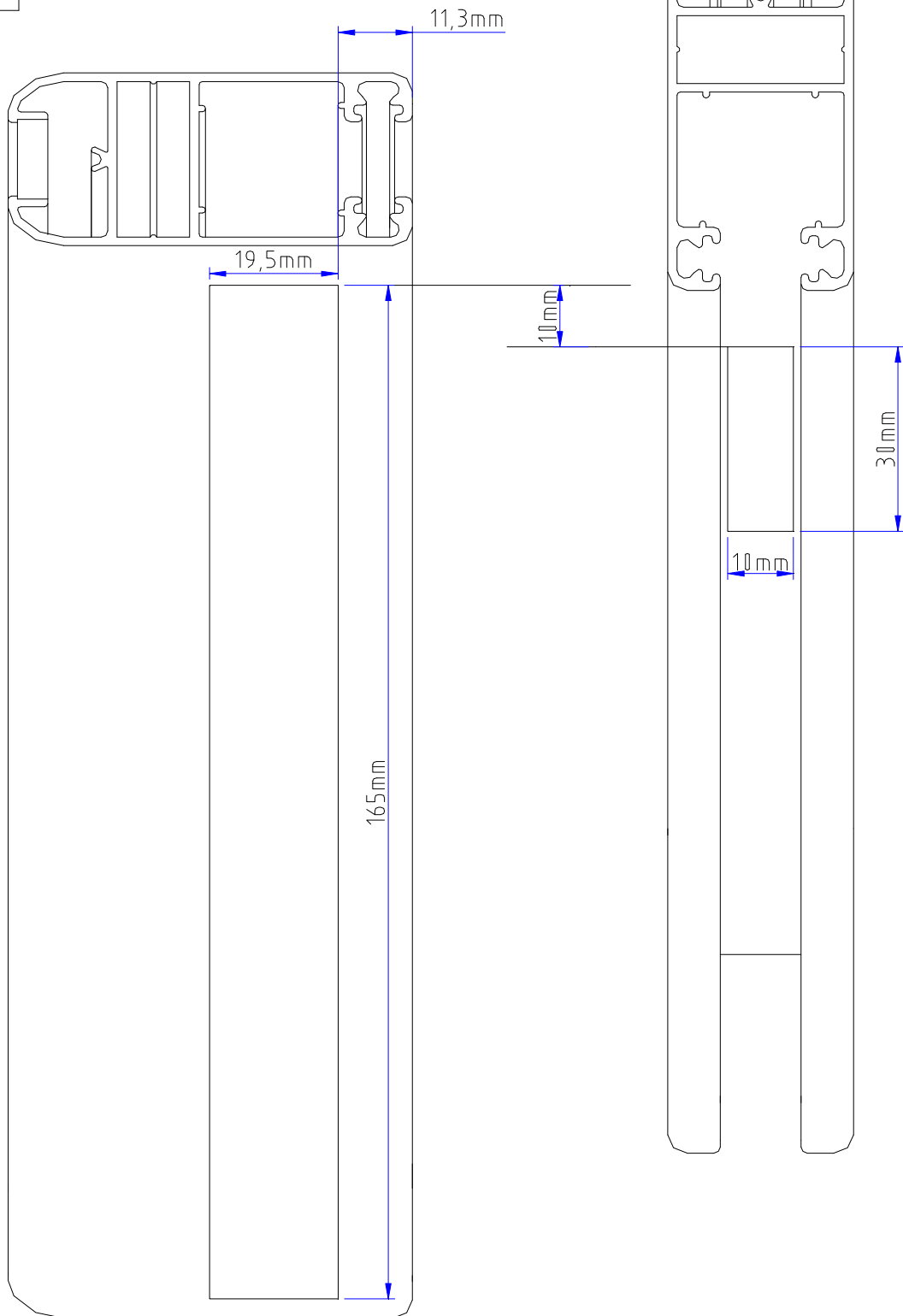

SEMANA: THE REPRODUCTION, DISTRIBUTION AND UTILIZATION OF THIS DOCUMENT AS WELL AS THE COMMUNICATION OF ITS CONTENTS TO OTHERS WITHOUT THE EXPRESS WRITTEN PERMISSION OF ROTO FRANK S.A. WILL BE HELD AS A VIOLATION OF PATENT RIGHTS AND WILL BE PROSECUTED IN THE EVENT OF THE GRANT OF A PATENT, UTILITY MODEL OR DESIGN.

E18/main / Entwicklung

			Scale	Perfiles: Aluar-
			1:1	
1	11-11-13	AB	Revision Samsa Andres	
Qty.	Date	Name	Roto Frank Latina S.A.	
Issue No.	RFL002	Replaces	DUO	
Effect Key	N		Sheet No. 1 of 1 Rev. No. E1	



Roto In-line Sliding

El sistemas de herraje para ventanas y puertas correderas

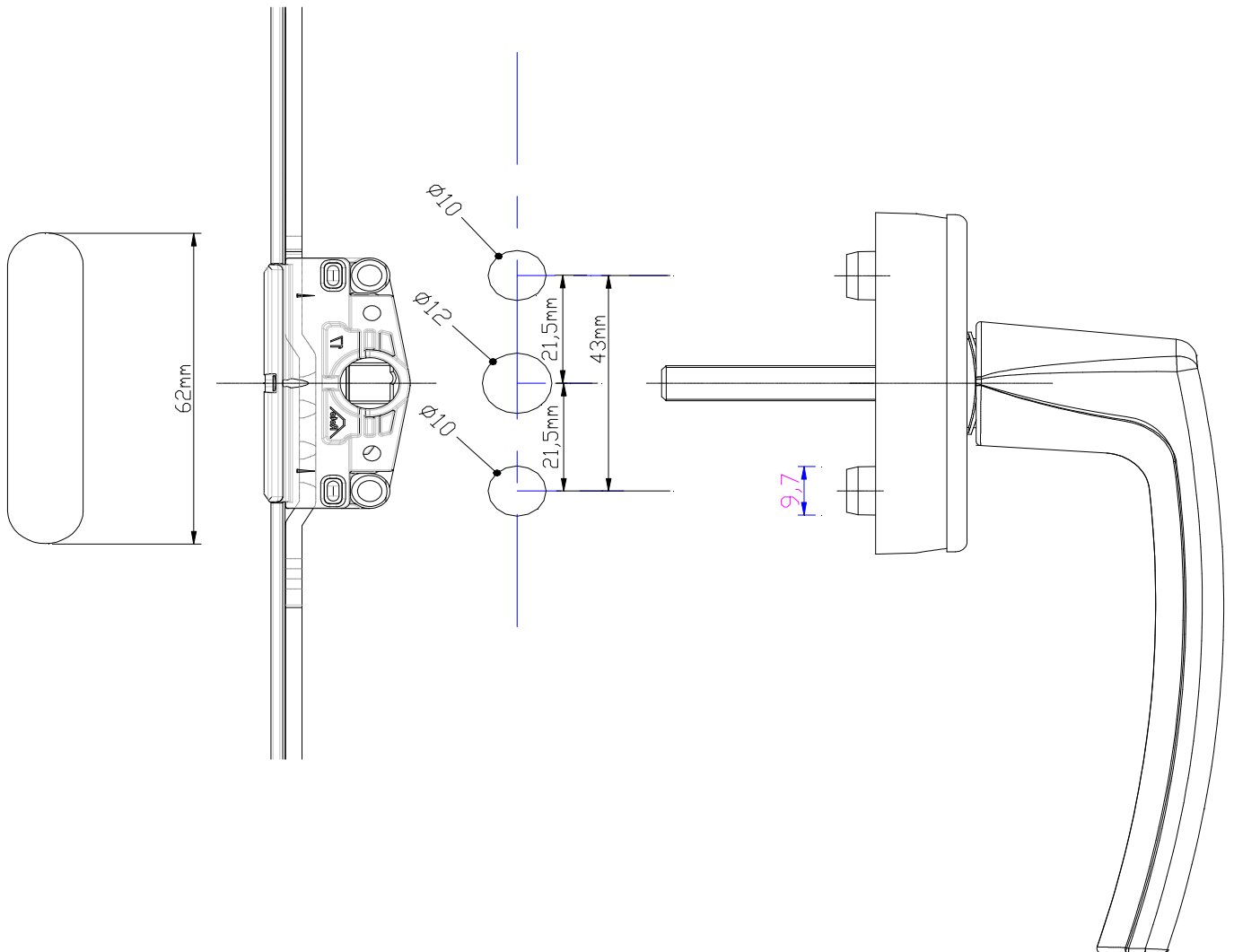

ADVERTENCIA IMPORTANTE: Los bujes salientes en la manija tienen como función principal asegurar el anclaje de la manija al perfil. Para esto, dichos bujes tienen un diámetro de 9,7mm que debe encastrar en los mecanizados de exactamente 10mm. Si el taladro se efectua con herramienta manual, verificar la terminación exacta o utilizar mecha de 9,85mm. De otra manera la manija presentara movimiento inadecuado por deficiente fijación.

TIPOS DE MECANISMOS SEGÚN ENTRADA DEL EJE DE MANIJA:

El mecanismo tiene puntos de anclaje según las dimensiones del mismo. Este determina la cantidad de suplementos a utilizar. Cada punto de anclaje debe llevar un punto de suplementación. Ejemplo: mecanismo de 600mm, 6 puntos de anclaje según tabla.

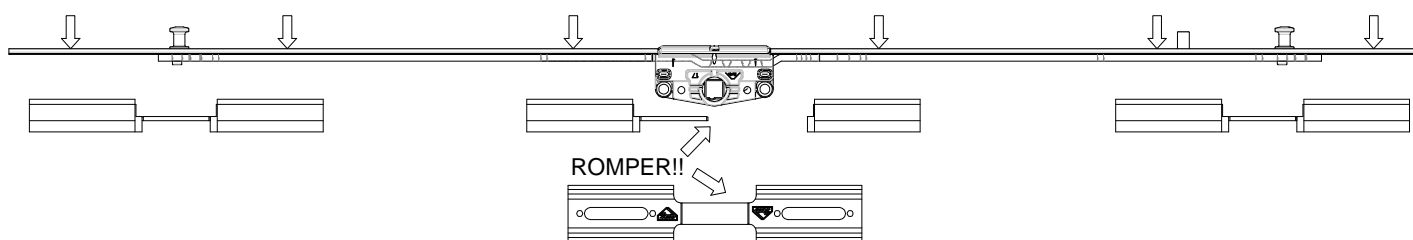

E15	MECANISMOS CON ENTRADA DE 15MM	medida	punts de cierre	puntos anclaje
628482	CREMONA CORR RotoSil B17 240mm 2 BULONES	240	2	2
628483	CREMONA CORR RotoSil B17 400mm 2 BULONES	400	2	4
628484	CREMONA CORR RotoSil B17 600mm 2 BULONES	600	2	6
628495	CREMONA CORR RotoSil B17 800mm 2 BULONES	800	2	6
628496	CREMONA CORR RotoSil B17 1000mm 3 BULONES	1000	3	8
628497	CREMONA CORR RotoSil B17 1200mm 3 BULONES	1200	3	9
628498	CREMONA CORR RotoSil B17 1800mm 4 BULONES	1800	4	12
628499	CREMONA CORR RotoSil B17 1800mm Con CILIN	1800	4	12

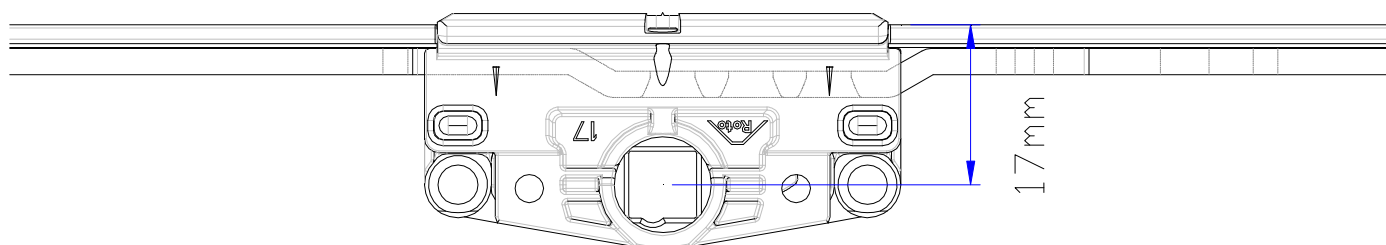

E7	MECANISMOS CON ENTRADA DE 7MM	medida	punts de cierre	puntos anclaje
628429	CREM. CORR RotoSil B7 400mm 2 BULONES	400	2	4
628430	CREM. CORR RotoSil B7 600mm 2 BULONES	600	2	6
628431	CREM. CORR RotoSil B7 800mm 2 BULONES	800	2	6
628432	CREM. CORR RotoSil B7 1000mm 3 BULONES	1000	3	8
628433	CREM. CORR RotoSil B7 1200mm 3 BULONES	1200	3	9
628434	CREM. CORR RotoSil B7 1800mm 4 BULONES	1800	4	12

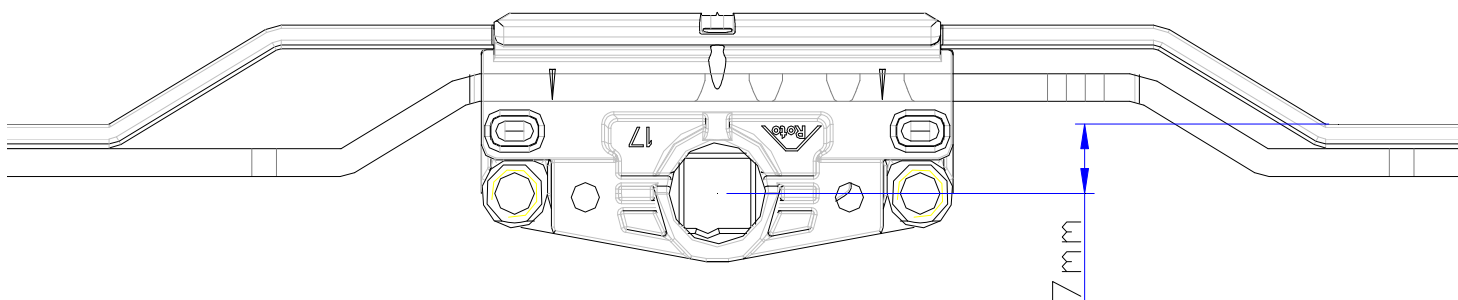

ESCUADRA PARA TRANSFERENCIA DEL PUNTO DE FIJACION DEL CERRADERO EN MARCO

Colocar la plantilla (631078) en la cremona

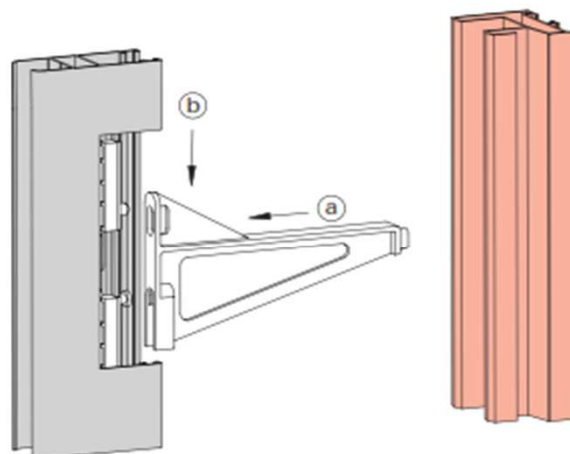

Poner el cerradero en la parte opuesta de la cremona, como muestra la imagen de la derecha.

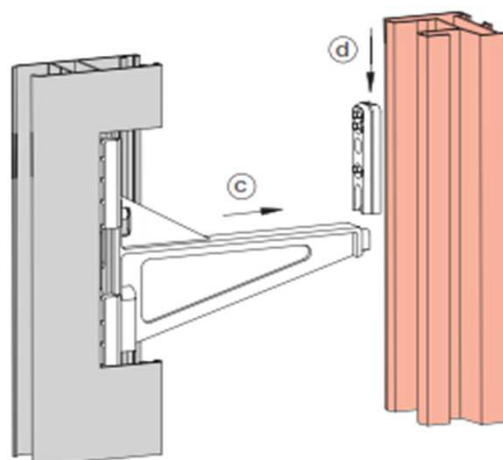

Hacer una marca en el marco. Fijar el cerradero con los tornillos con una presión de 1.5 –2Nm y clipar el embellecedor de plástico. .

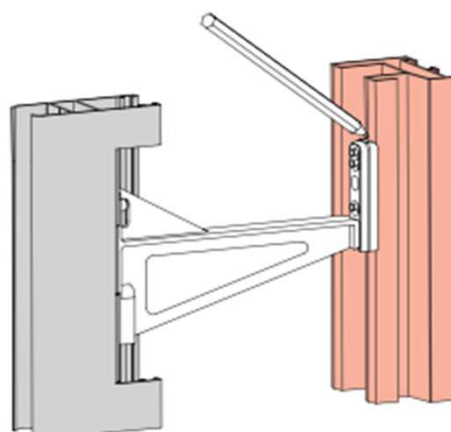

MANIJAS MULTIPUNTO ACODADAS

SISTEMA: ROTO MULTIPUNTO

- 228043 MANIJA ROTO-LINE c/tor BLANCO 35c/Llave
228040 MANIJA ROTO-LINE c/tor TITAN 35c/Llave



- 375816 MANIJA ACODADA R-LINE BLANCO DER 43mm
375320 MANIJA ACODADA R-LINE BLANCO IZQ 43mm
570510 MANIJA ACODAD s/eje R-LINE NEGR IZQ 43mm
570511 MANIJA ACODAD s/eje R-LINE NEGR DER 43mm
375319 MANIJA ACODADA R-LINE TITAN IZQ 43mm
375814 MANIJA ACODADA R-LINE TITAN DCH 43mm



UÑEROS DE EMBUTIR POP-UP

SISTEMA: ROTO MULTIPUNTO

570810	UÑERO POP-UP 8mm S26 BCO R07.2
614295	UÑERO POP-UP 8mm S26 NEGR R06.2
637963	UÑERO POP-UP 8mm S26 PLATA R01.1



MANIJON MULTIPUNTO CON CUBETA EXT

SISTEMA: ROTO MULTIPUNTO

JUEGO DE MANIJONES PARA CORREDIZAS

613226	MANIJON TIRADOR INT / CUBETA EXT BLANCO (conformado x estas tres piezas)
605543	
613181	

613225	MANIJON TIRADOR INT / CUBETA EXT NEGRO
605551	
613181	

613222	MANIJON TIRADOR INT / CUBETA EXT PLATA
613183	
613181	

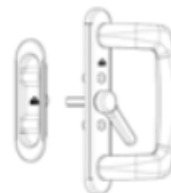

MANIJON MULTIPUNTO CON PALANCA

SISTEMA: ROTO MULTIPUNTO

JUEGO DE MANIJONES PARA CORREDIZAS

613226	MANIJON TIRADOR INT / EXT CON PALANCA BLANCO (conformado x estas tres piezas)
613191	
613181	

613225	MANIJON TIRADOR INT / EXT C/PALANCA NEGRO
613190	
613181	

613222	MANIJON TIRADOR INT / EXT C/ PALANCA PLATA
613187	
613181	

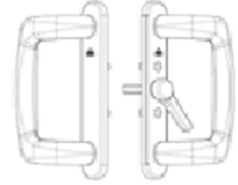

MANIJON MULTIPUNTO con CILINDRO

SISTEMA: ROTO MULTIPUNTO

JUEGO DE MANIJONES PARA CORREDIZAS

613243	MANIJON TIRADOR INT / EXT CON CILINDRO BLANCO (conformado x estas tres piezas)
613217	
613181	

613242	MANIJON TIRADOR INT / EXT CON CILIND NEGRO
613216	
613181	

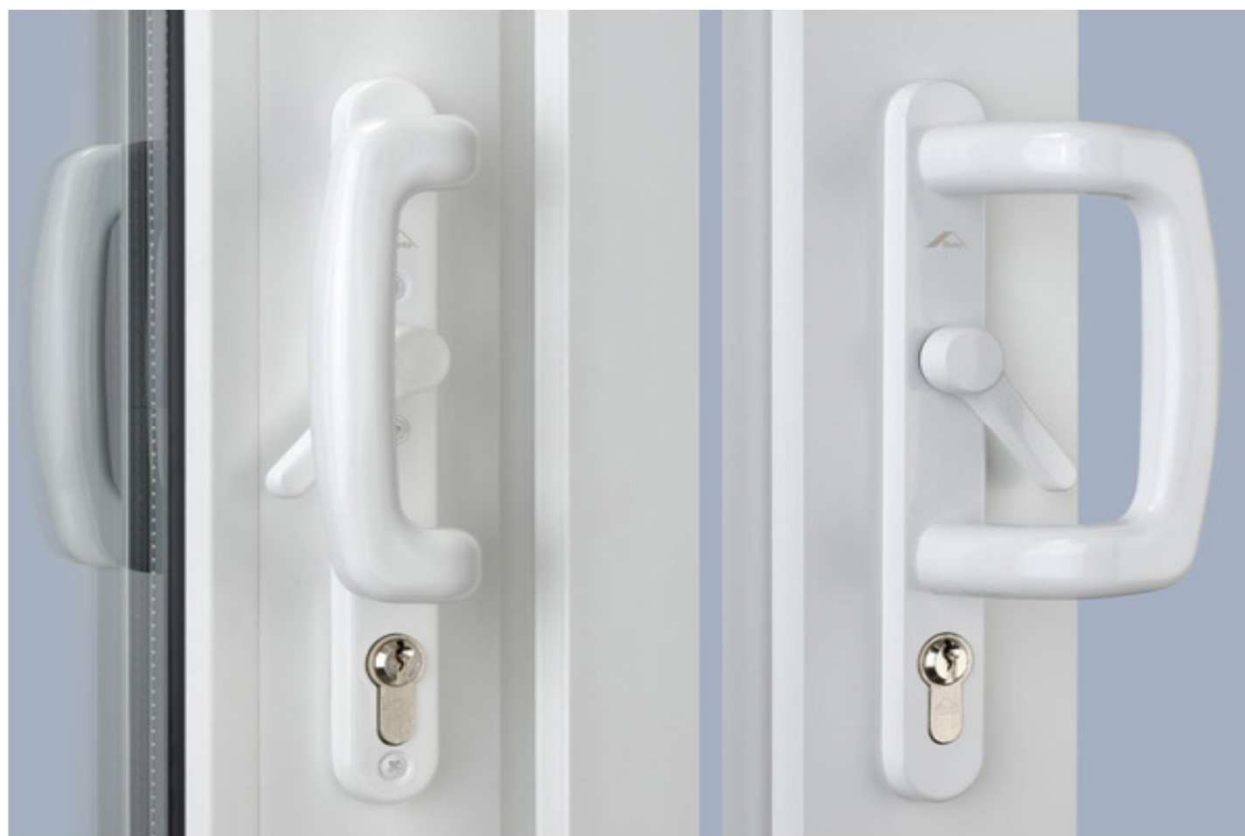
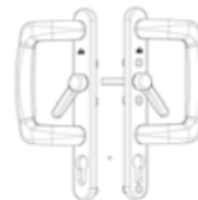

613239	MANIJON TIRADOR INT / EXT CON CILINDRO PLATA
613203	
613181	



Multipunto en MODENA 45°

SISTEMA: ROTO MULTIPUNTO

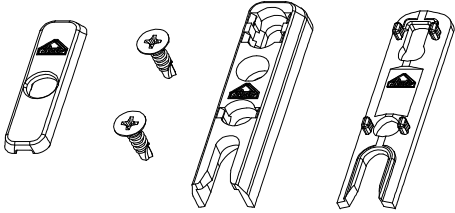
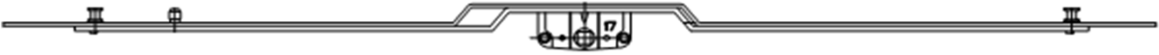
Lista de herrajes para montar Roto Multipunto en: MODENA 45

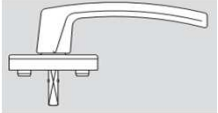
CODIGO	DESCRIPCION	
478413	KIT CERRADEROS MULTIPUNTO ROTO 12mm	
		
628429	CREM. CORR RotoSil B7 400mm 2 BULONES	
628430	CREM. CORR RotoSil B7 600mm 2 BULONES	
628431	CREM. CORR RotoSil B7 800mm 2 BULONES	
628432	CREM. CORR RotoSil B7 1000mm 3 BULONES	
628433	CREM. CORR RotoSil B7 1200mm 3 BULONES	
628434	CREM. CORR RotoSil B7 1800mm 4 BULONES	
		
478411	CALZO S002 ALTURA 11mm P/CREM CORR (PAQ. X 3 CALZOS)	
490546	MANILLA ROTO-LINE c/tor NEG 24c/Log	
490545	MANILLA ROTO-LINE c/tor BCO 24c/Log	
339532	MANILLA ROTO-LINE c/tor TITAN 30c/Log	

VENTANA Y PUERTA CORREDIZA MODENA a 45°

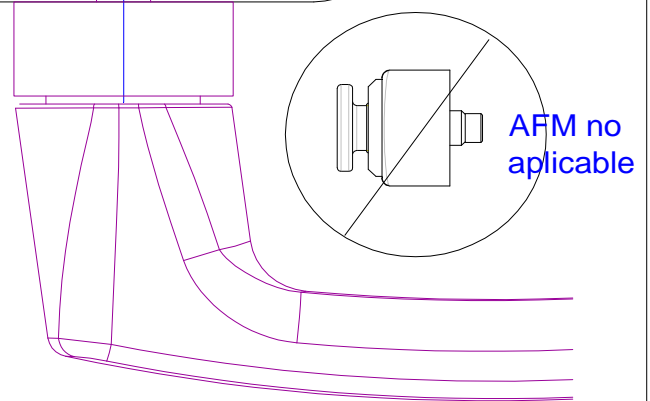
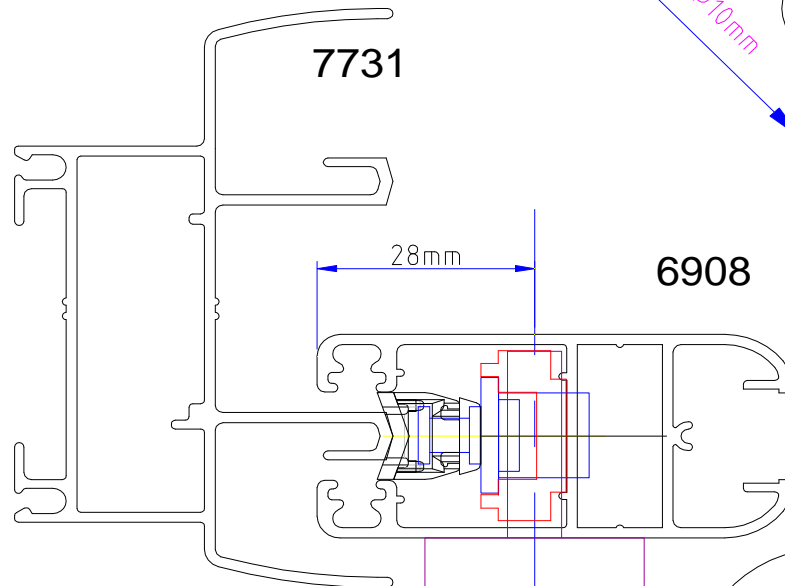
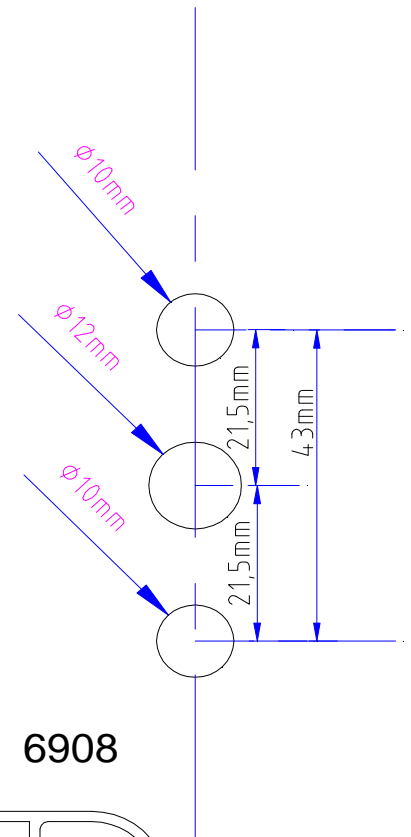
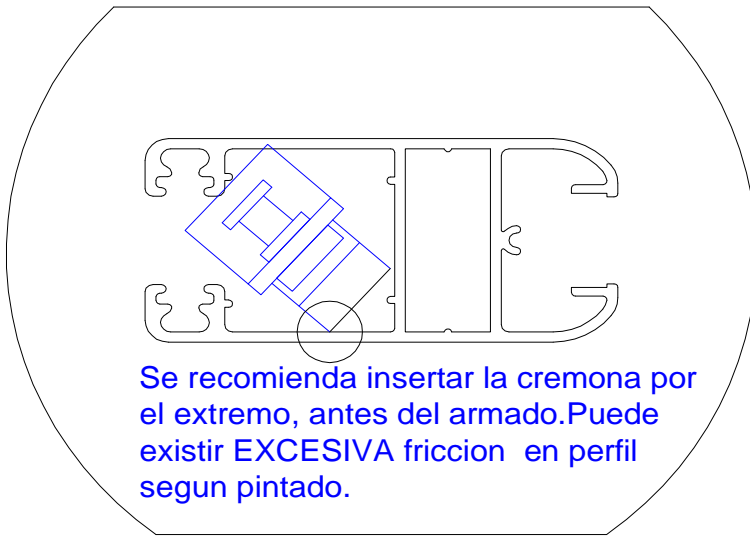

Nota:
Ver grafico de calado felpas.
No avalado por Roto Frank

FOR THE REPRODUCTION, DISTRIBUTION AND UTILIZATION OF THE CONTENTS OF THIS DOCUMENT, THE USER SHALL BE RESPONSIBLE FOR THE PAYMENT OF DAMAGES. ALL RIGHTS RESERVED IN THE EVENT OF THE VIOLATION OF PATENT, UTILITY MODEL, OR DESIGN.

E1.8/main / Entwicklung

Qty.	Date	Name	Revision
1	11-11-13	AB	Samsa Andres
Issue No.		Replaces	
Effect Key	N		

Scale
1:1

Perfiles: Aluar-

Roto Frank Latina S.A.

Multipunto



Sheet No. 1 of 1 Rev. No. E1

VENTANA Y PUERTA CORREDIZA MODENA a 45° MECANIZADO PARA MONTAJE

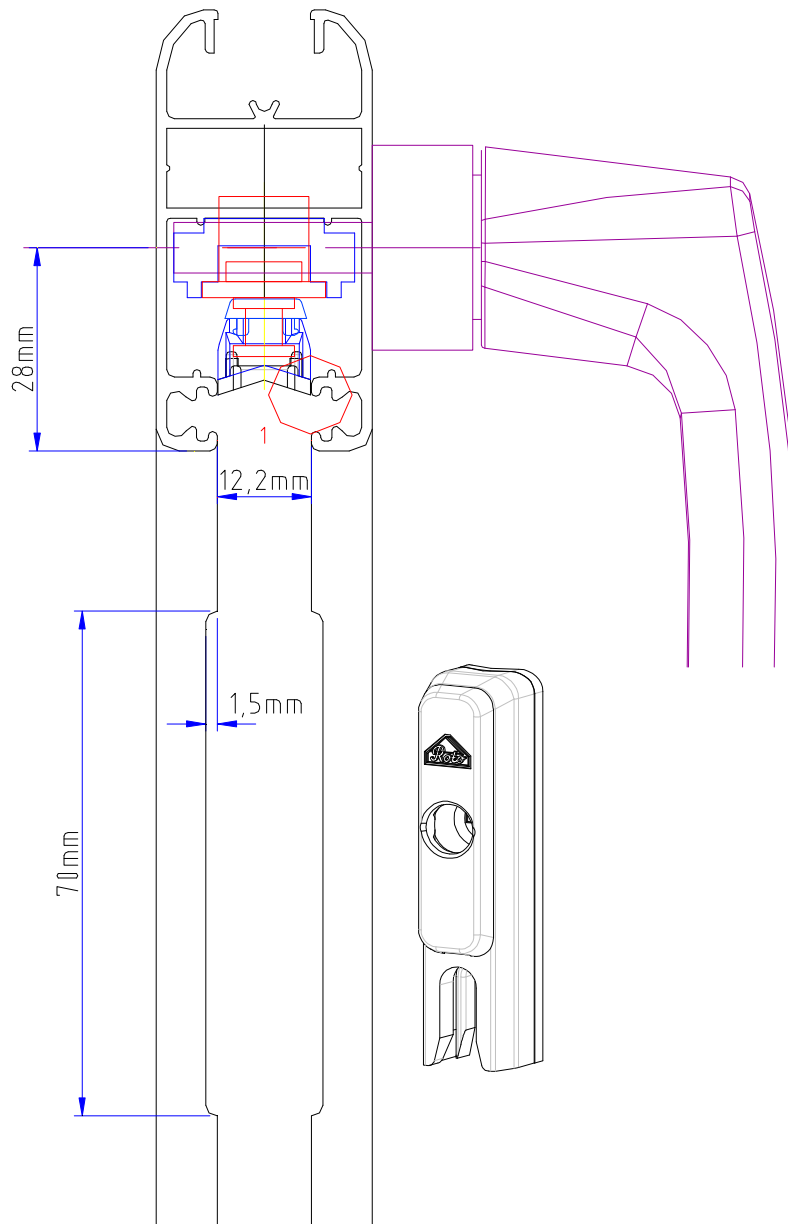

Nota:

1 -El rozamiento del cerradero de 12mm puede afectar la prestacion de la felpa debiendose calar alojamiento de felpa segun grafico. No avalado por Roto Frank.

ALL RIGHTS RESERVED. REPRODUCTION AND USE IN ANY FORM OF THE
 DOCUMENT AS WELL AS THE COMMUNICATION OF ITS CONTENTS TO OTHERS
 WITHOUT EXPRESS AUTHORIZATION IS PROHIBITED. REPRODUCERS WILL BE
 RESPONSIBLE FOR ANY DAMAGES CAUSED BY SUCH REPRODUCTION AND
 THE EVENT OF THE GRANT OF A PATENT, UTILITY MODEL OR DESIGN.

E18/main / Entwicklung

-			-		Scale	Perfiles: Aluar-
1	11-11-13	AB	-		1:1	
Qty.	Date	Name	Revision		Roto Frank Latina S.A.	
1	11-11-13	AB	Revision Samsa Andres		Multipunto	
Issue No.	-	Replaces	-		Sheet No. 1 of 1	
Effect Key	N		-		Rev. No. E1	



HOJA PASIVA CORREDIZA MODENA a 45°

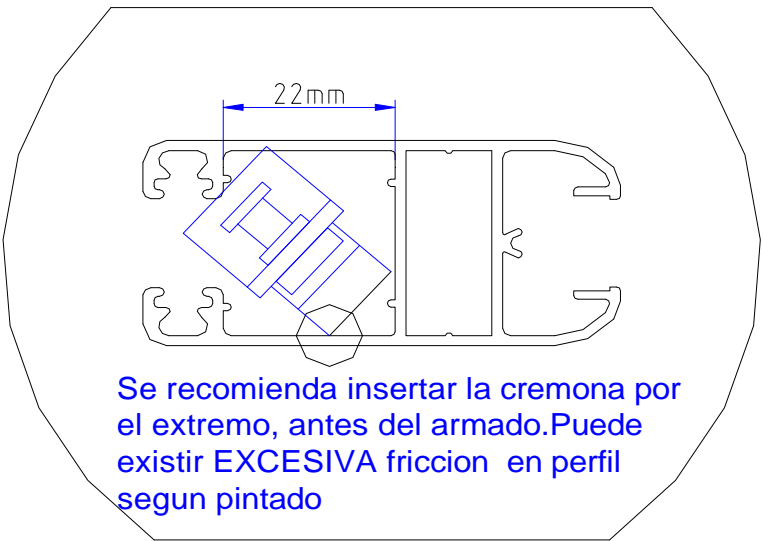

Se recomienda insertar la cremona por el extremo, antes del armado. Puede existir EXCESIVA fricción en perfil según pintado

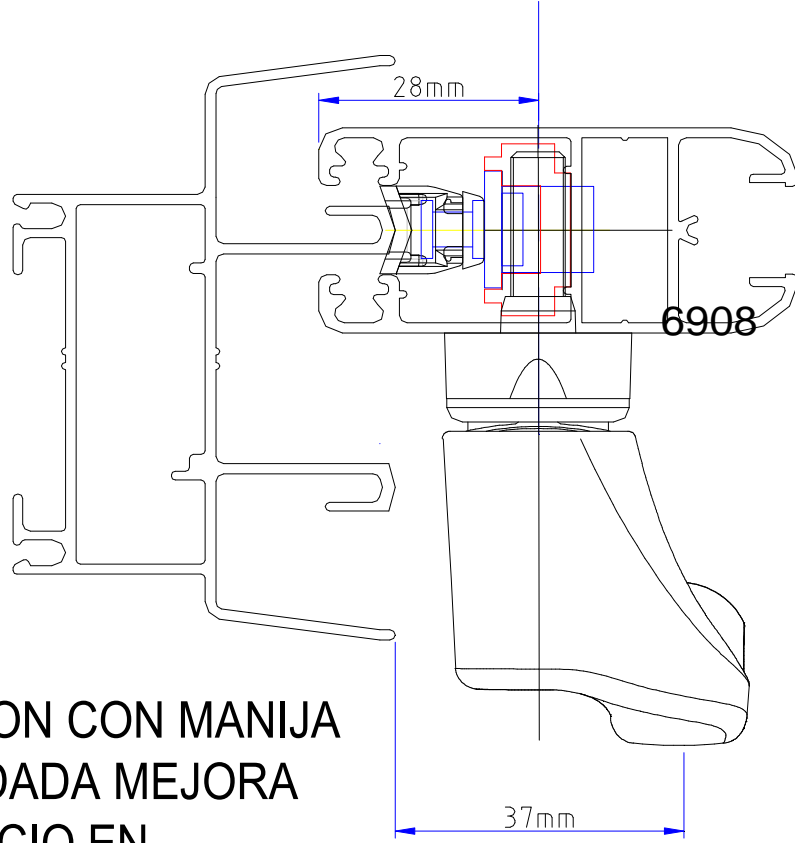

OPCION CON MANIJA ACODADA MEJORA ESPACIO EN SEGUNDA HOJA

(WARNING: THE REPRODUCTION, DISTRIBUTION AND UTILIZATION OF THIS DOCUMENT AS WELL AS THE COMMUNICATION OF ITS CONTENTS TO OTHERS WITHOUT EXPRESS AUTHORIZATION FROM ROTO FRANK S.A. IS PROHIBITED. IN THE EVENT OF THE GRANT OF A PATENT, UTILITY MODEL OR DESIGN.

E18/main / Entwicklung

-			-		Scale	Perfiles: Aluar-
1			11-11-13		1:1	
Qty.	Date	Name	Revision		Roto Frank Latina S.A.	
1	11-11-13	AB	Samsa Andres		Multipunto	
Issue No.	-	Replaces	-		-	
Effect Key	N	-		-		Sheet No. 1 of 1 Rev. No. E1



Multipunto en A40 hoja 45°

SISTEMA: ROTO MULTIPUNTO

CODIGO DESCRIPCION

478413 KIT (par) CERRADEROS MULTIPUNTO ROTO 12mm

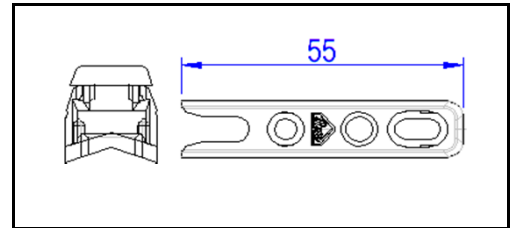
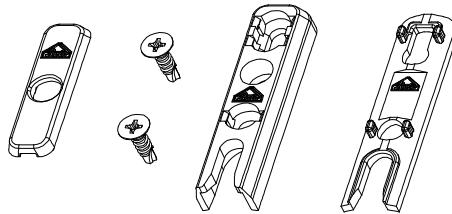

MECANISMO CORREDERA BACKSET 17MM,

- 628482 CREMONA CORR RotoSil B17 240mm 2 BULONES
- 628483 CREMONA CORR RotoSil B17 400mm 2 BULONES
- 628484 CREMONA CORR RotoSil B17 600mm 2 BULONES
- 628495 CREMONA CORR RotoSil B17 800mm 2 BULONES
- 628496 CREMONA CORR RotoSil B17 1000mm 3 BULONES
- 628497 CREMONA CORR RotoSil B17 1200mm 3 BULONES
- 628498 CREMONA CORR RotoSil B17 1800mm 4 BULONES

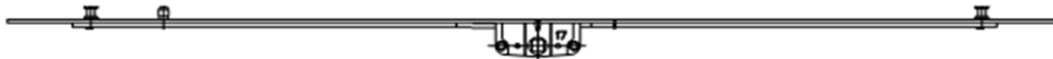

478412 CALZO S003 ALTURA 12,7mm P/CREM CORR (PAQ. X 6 CALZOS)



564313 CALZO S006 20,7mm (paq. X 3 calzos)



- 490546 MANILLA ROTO-LINE c/tor NEG 24c/Log
- 490545 MANILLA ROTO-LINE c/tor BCO 24c/Log
- 339532 MANILLA ROTO-LINE c/tor TITAN 30c/Log

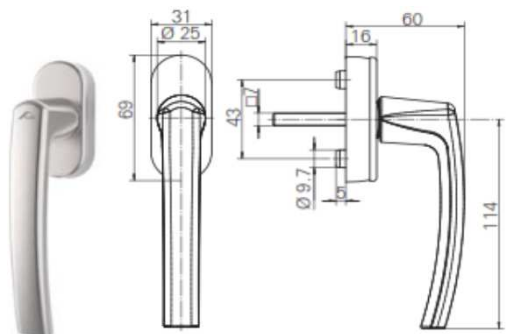

OPCION MECANISMO CORREDERA BACKSET 17MM CON CILINDRO (NECESARIO USAR CON MANIJON)

628499 CREMONA CORR RotoSil B17 1800mm Con CILIN 4 bul

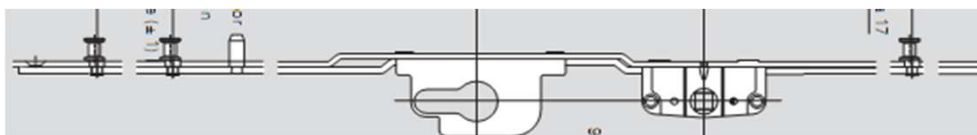

640069 CILINDRO NICKELADO 31 X 31

Multipunto en A40 hoja 45°

SISTEMA: ROTO MULTIPUNTO

CODIGO DESCRIPCION

MANIJA ACODADA, SEGÚN MANO, SEGÚN COLOR
VER PAG. 8

VER PLANO MONTAJE

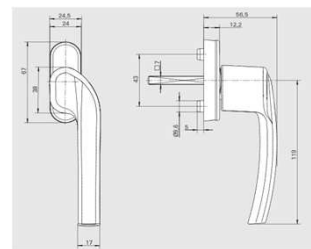

MANIJAS MULTIPUNTO 170MM GÚN COLOR

626524 MAN. R-LINE 170mm NEGRA (R06.2 -PATIO 200S)
211596 MAN. R-LINE 170mm BCA (R7.2 -PATIO 150S)
288728 MAN. R-LINE 170mm TITAN (R01.3 -PATIO 150S)



Uñero Pop-up para accionamiento de hoja pasiva

UÑERO CON MANIJA POP-UP

ver pagina 9

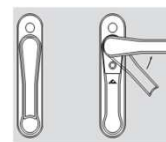

MANIJONES TIRADORES SEGÚN NECESIDAD, SEGÚN COLOR

MANIJON TIRADOR CON PALANCA + UÑERO

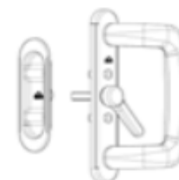

MANIJON TIRADOR DOBLE CON PALANCA

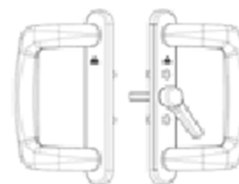

MANIJON TIRADOR DOBLE CON PALANCA y CILINDRO

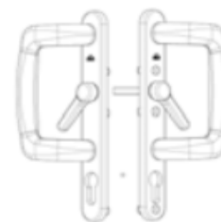

(PAG 10, 11, 12)

A40 Corte 45° supl NUEVO

**CALZO
NUEVO!!!**

**564313
20,7mm**

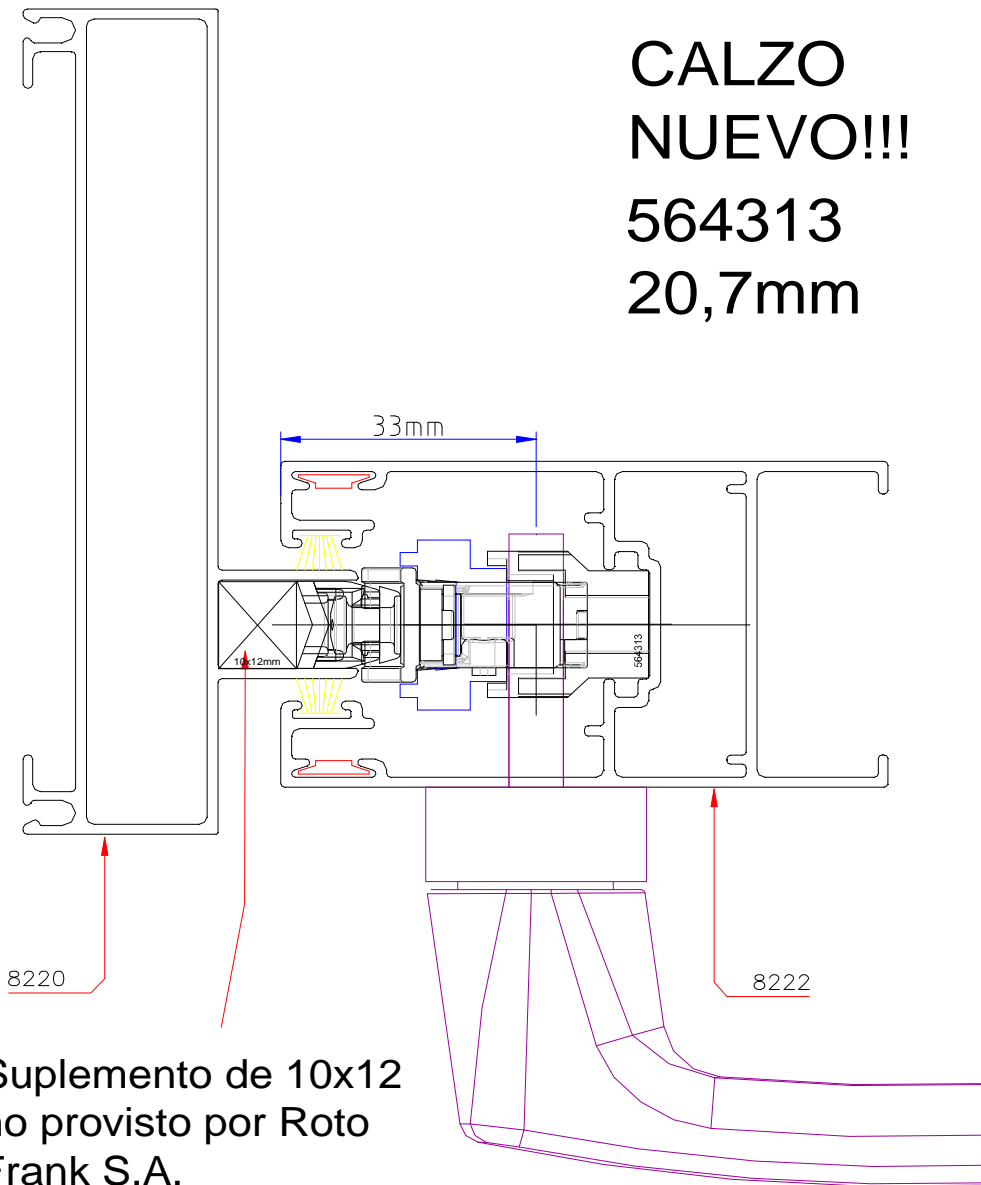

564313 CALZO S006 20,7mm

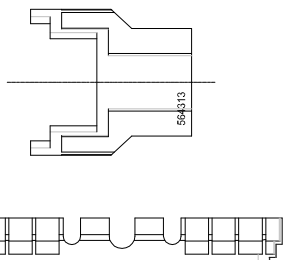

564313 + 478411 32mm

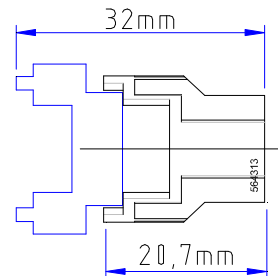

-	-	-	-
1	2014	AB	-
Qty.	Date	Name	Revision
	Revised		Andres Samsa
Issue No.	RFL 010	Replaces	-
Effect Key	N		-

Scale	1:1	Perfiles:
Roto Frank Latina S.A.		
Sheet No.	1 of 1	Rev. No. E1



Mecanizado en A40 CON EJE A 33mm

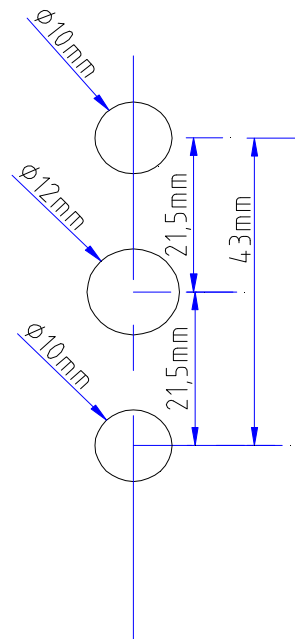
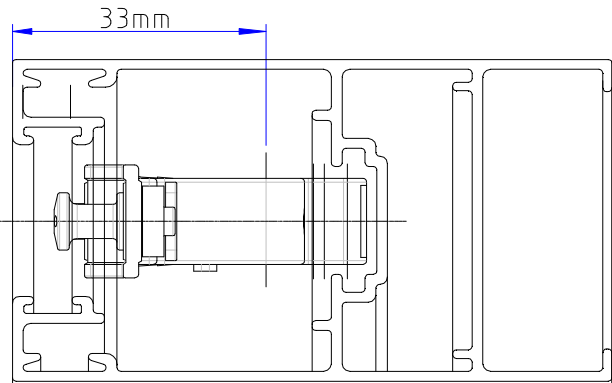
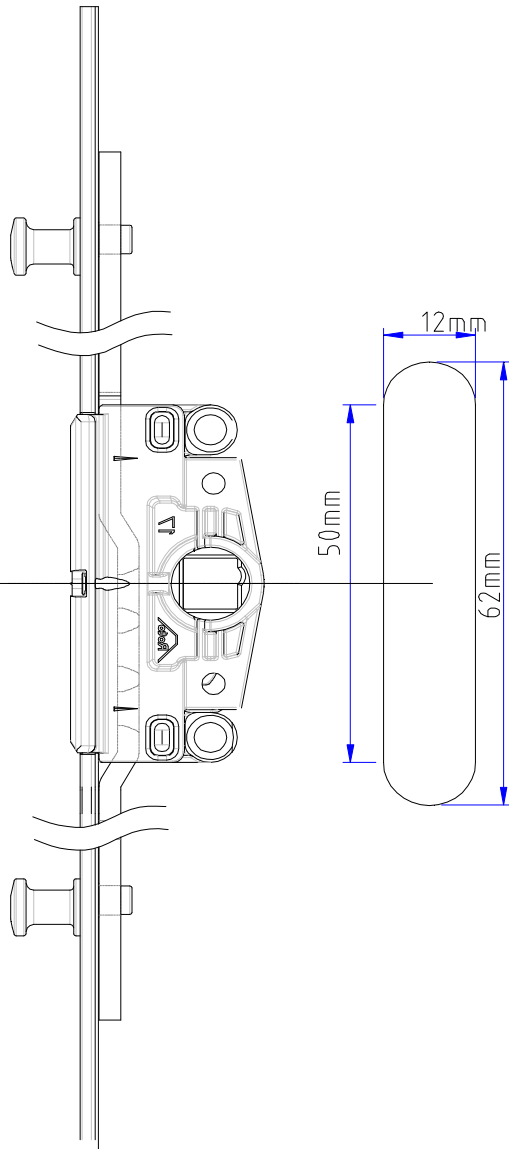

Qty.	Date	Name
	Revised	

Revision **Andres Samsa**

Roto Frank Latina S.A.

Issue No.	RFL010	Replaces	-
-----------	--------	----------	---

Effect Key	N		-
------------	---	--	---



Sheet No. 1 of 1

Rev. No. E1

A40 Corte 45° version con suplementos estandar Roto Frank

Opcional uñero pop-up de embutir

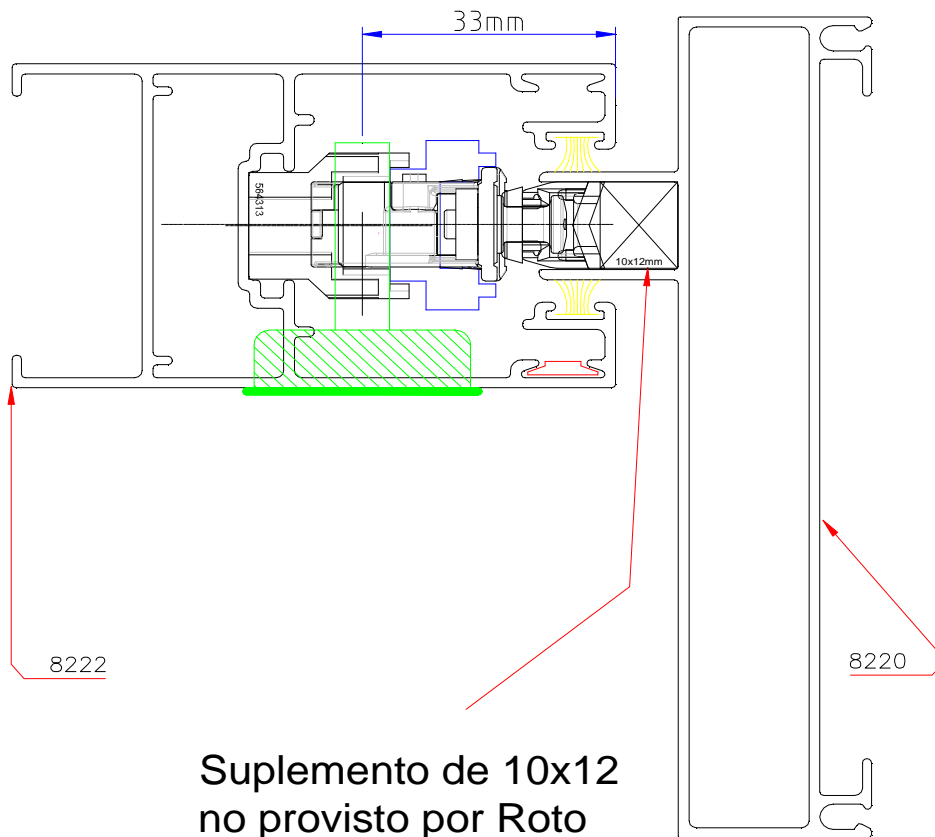

Suplemento de 10x12
no provisto por Roto
Frank S.A.

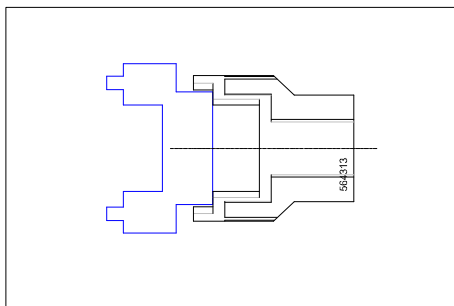

-		-		Scale	Perfiles:
-		-		1:1	
1	2014	AB			
Qty.	Date	Name	Revision	Andres Samsa	Roto Frank Latina S.A.
Issue No.	RFL010	Replaces	-		
Effect Key	N		-		



Corte 45° version con suplementos estandar Roto Frank

Mecanizado pop-up de embutir

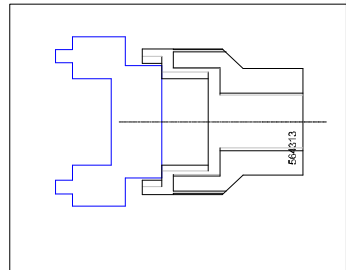
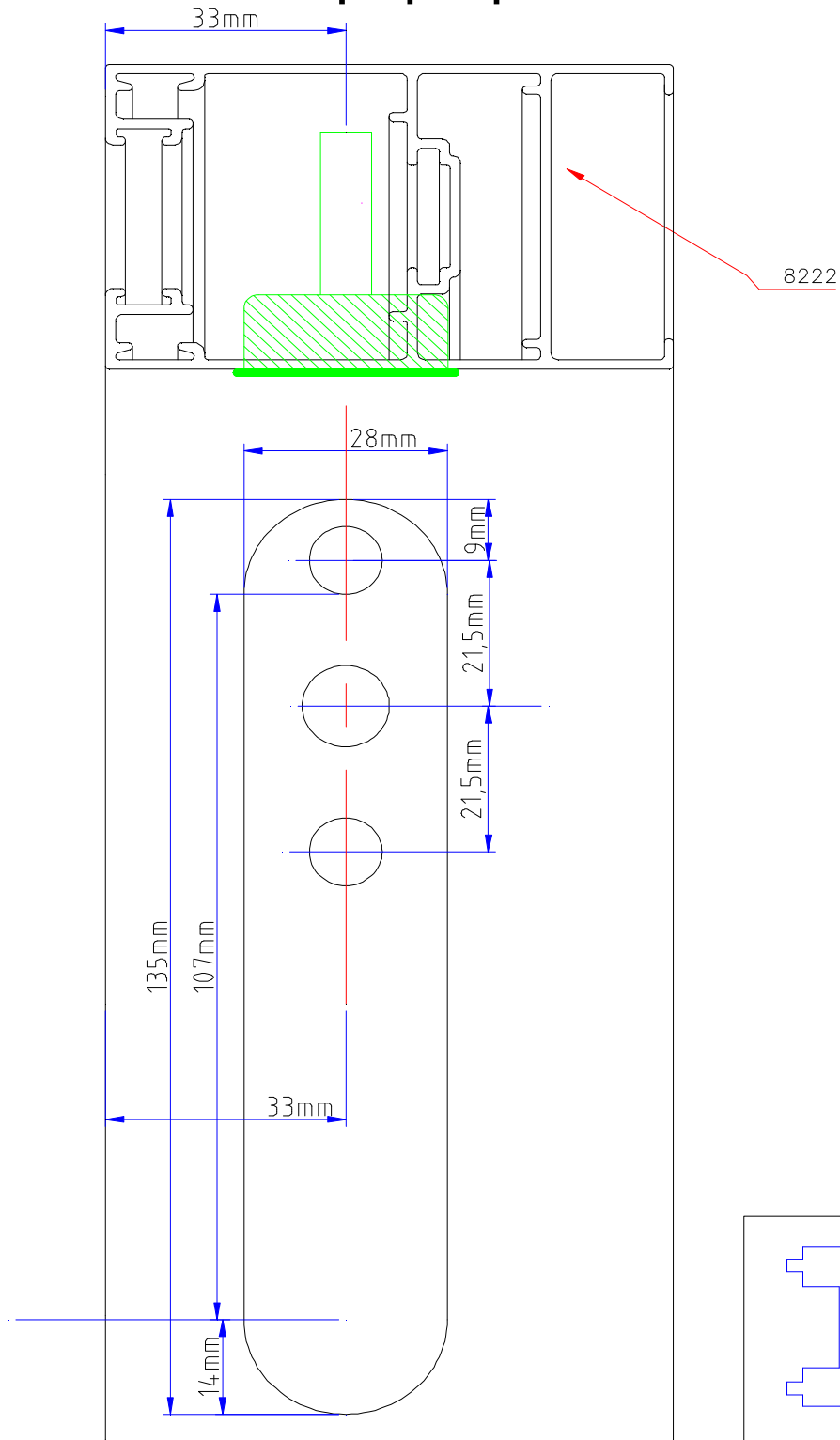

				Scale	Perfiles:
				1:1	
1	2014	AB			
Qty.	Date	Name	Revision	Andres Samsa	Roto Frank Latina S.A.
	Revised				
Issue No.	RFL010	Replaces	-		
Effect Key	N		-		



Mecanizado CERRADURA CON CILINDRO 628499 en A40

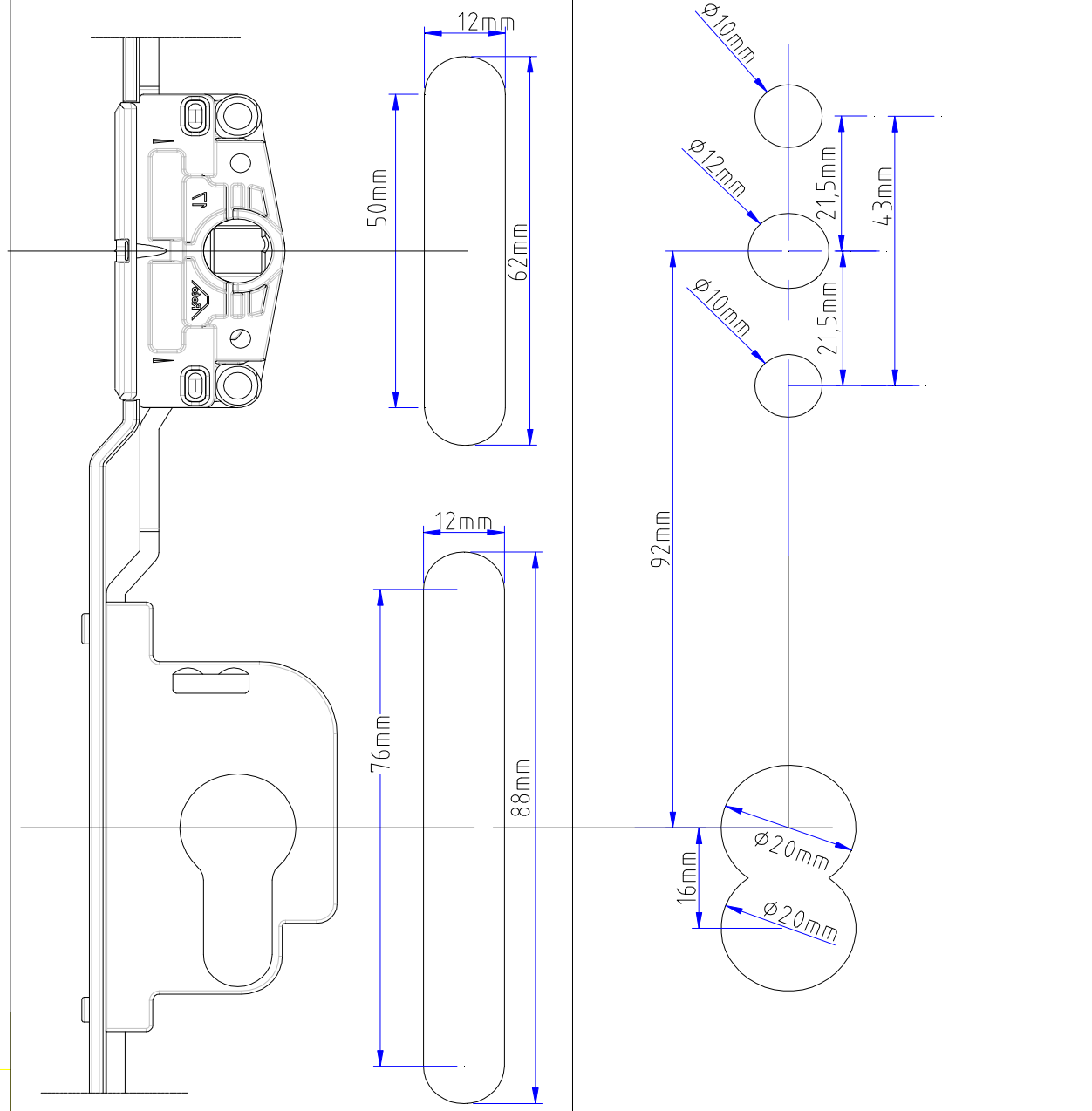

Qty.	Date	Name	Revision	Andres Samsa	Roto Frank Latina S.A.
	Revised				
Issue No.	RFL010	Replaces	-		
Effect Key	N		-		



VESTA

SISTEMA: ROTO MULTIPUNTO

CODIGO	DESCRIPCION			
--------	-------------	--	--	--

478413	KIT CERRADEROS MULTIPUNTO ROTO 12mm			
--------	-------------------------------------	--	--	--

628429	CREM. CORR RotoSil B7 400mm 2 BULONES			
628430	CREM. CORR RotoSil B7 600mm 2 BULONES			
628431	CREM. CORR RotoSil B7 800mm 2 BULONES			
628432	CREM. CORR RotoSil B7 1000mm 3 BULONES			
628433	CREM. CORR RotoSil B7 1200mm 3 BULONES			
628434	CREM. CORR RotoSil B7 1800mm 4 BULONES			

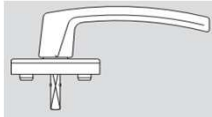

478412	CALZO S003 ALTURA 13,7mm P/CREM CORR (PAQ. X 3 CALZOS)			
--------	--	--	--	--

490546	MANILLA ROTO-LINE c/tor NEG 24c/Log			
490545	MANILLA ROTO-LINE c/tor BCO 24c/Log			
339532	MANILLA ROTO-LINE c/tor TITAN 30c/Log			

MANIJA ACODADA, SEGÚN MANO, SEGÚN COLOR
VER PAG. 8

VER PLANO MONTAJE

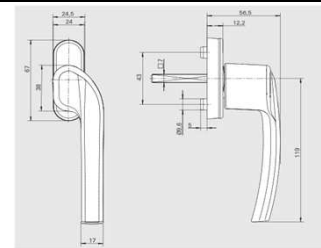

TOPE DE FIN DE CARRERA - TODAS LAS LINEAS (SOLO BLANCO Y NEGRO, GOMA NEGRA)

335555 TOPE CORREDERA NEGRO (ALU)
317250 TOPE CORREDERA BLANCO (ALU)



OPCIONAL SEGURIDAD INTERNA MANIJA CON LLAVE

228040 MANILLA ROTO-LINE c/tor TITAN 35c/Llave
228043 MANILLA ROTO-LINE c/tor BLANCO 35c/Llave



VENTANA Y PUERTA CORREDIZA VESTA

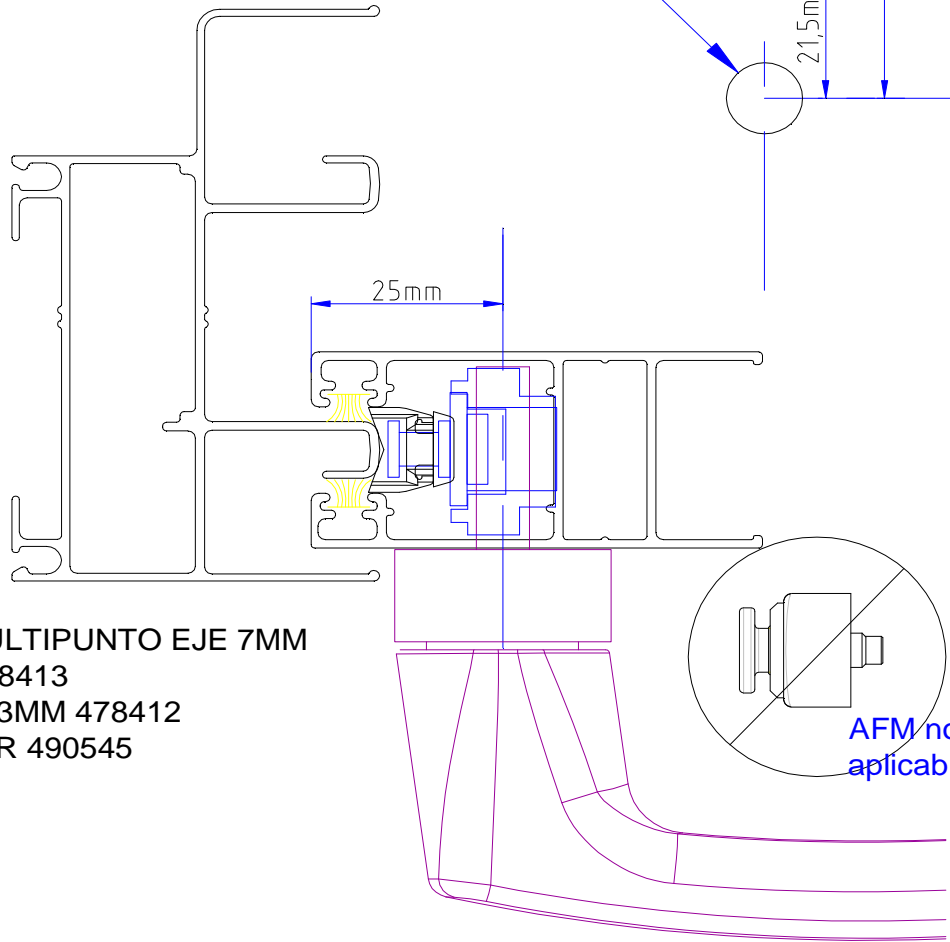
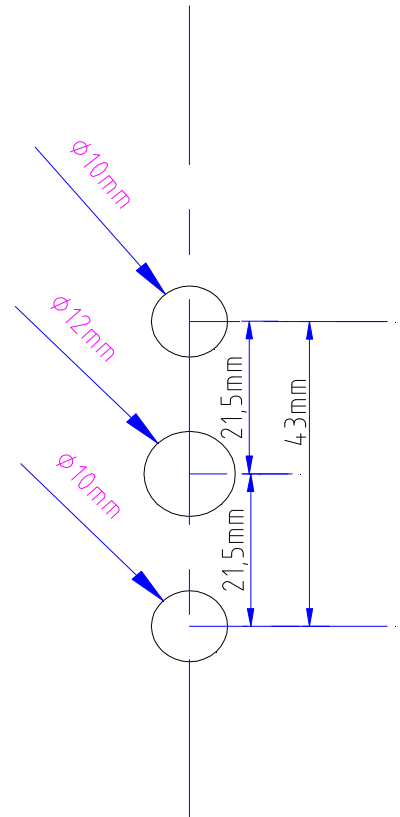
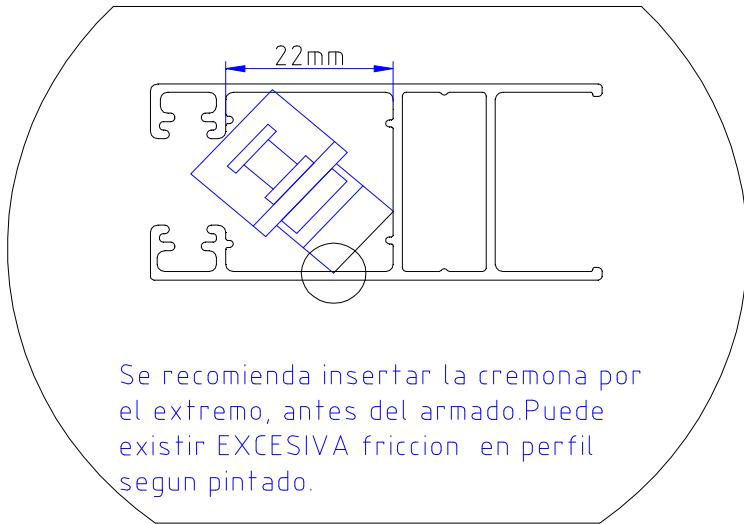

MECANISMO MULTIPUNTO EJE 7MM
 CERRADERO 478413
 SUPLEMENTO 13MM 478412
 MANIJA S/COLOR 490545

E.18/main / Entwicklung

-	-	-	-
1	29-7-08	AB	-
Qty.	Date	Name	Revision
	Revised		
Issue No.	-	Replaces	-
Effect Key	N		-

Scale

1:1

Perfiles: Aluar-

Multipunto



Sheet No.

1

of

1

Rev. No.

E1

CORREDIZA VESTA - SE RECOMIENDA MECANIZAR HOJA

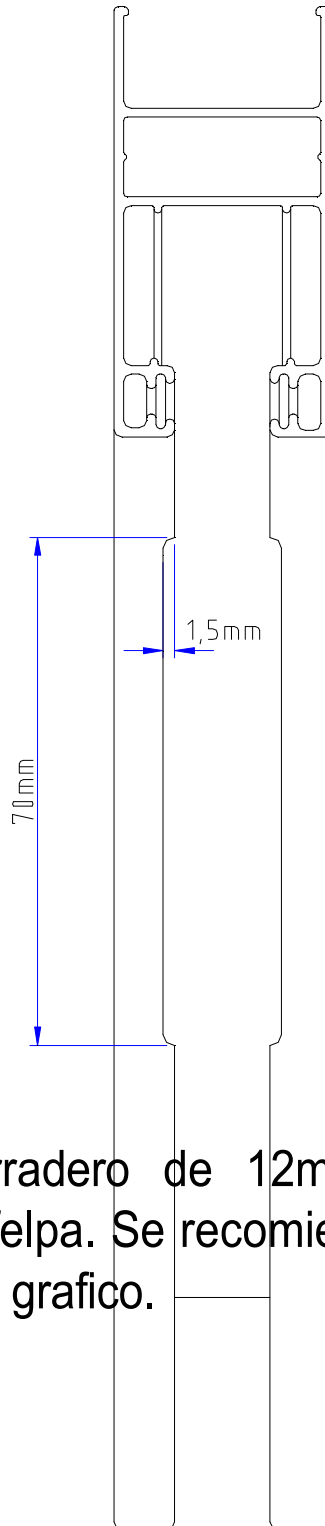
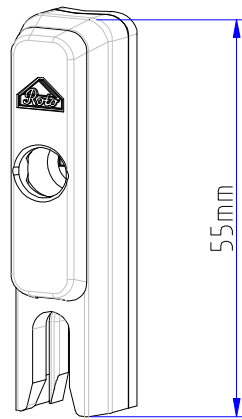

Nota:

1 -El rozamiento del cerradero de 12mm puede afectar la prestacion de la felpa. Se recomienda calar alojamiento de felpa segun grafico.

E18/main / Entwicklung

-	-	-	-
1	29-7-08	AB	-
Qty.	Date	Name	Revision
	Revised		
Issue No.	-	Replaces	-
Effect Key	N		-

Scale

1:1

Perfiles: Aluar-

Multipunto



Sheet No. 1 of 1

Rev. No. E1

CORREDIZA VESTA - hoja pasiva con manija ACODADA

- Mejora acceso a la manija

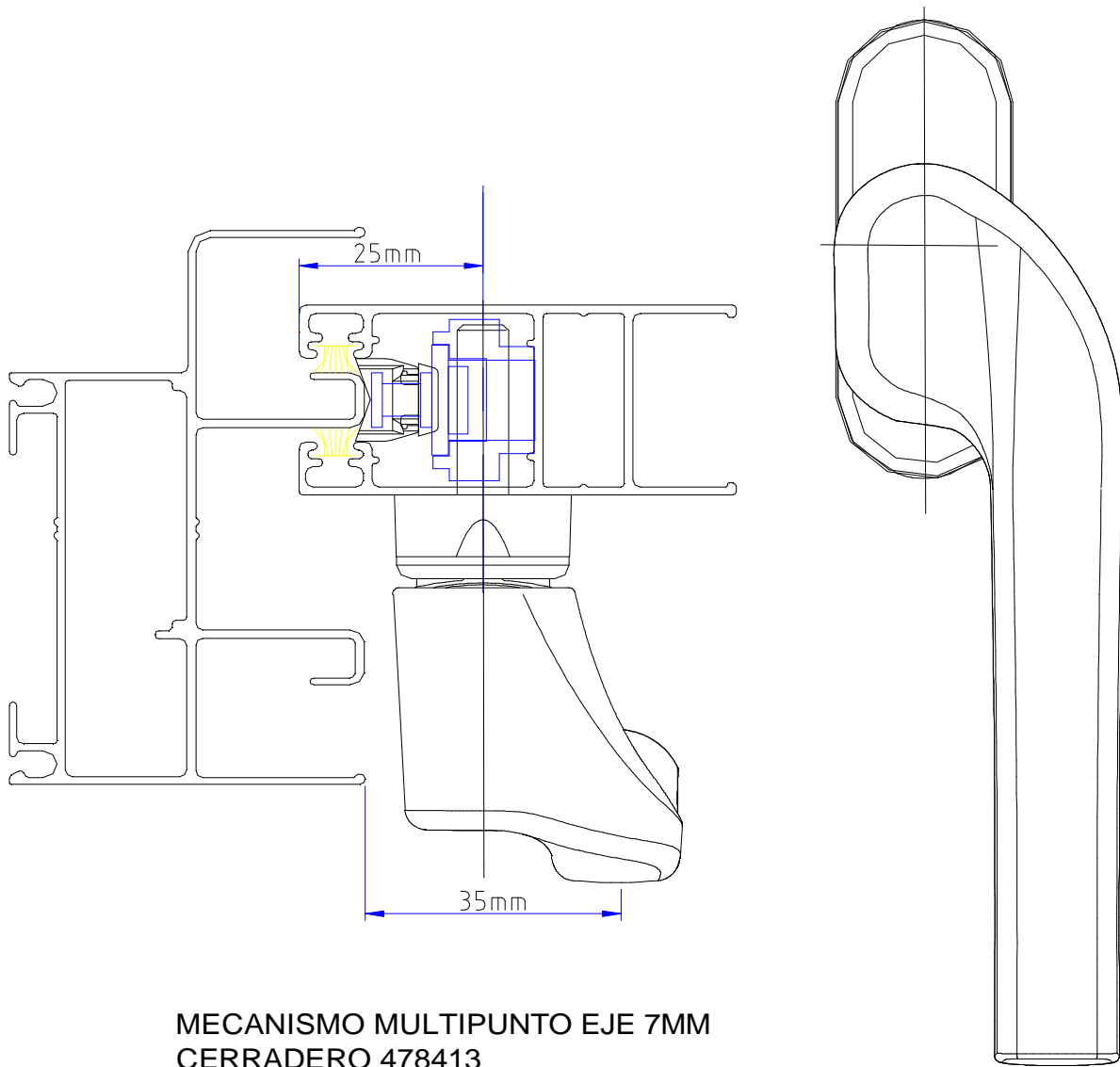

MECANISMO MULTIPUNTO EJE 7MM
 CERRADERO 478413
 SUPLEMENTO 13MM 478412
 MANIJA S/COLOR

E18/main / Entwicklung

	-	-	
	-	-	
1	29-7-08	AB	-
Qty.	Date	Name	
	Revised		Revision
Issue No.	-	Replaces	-
Effect Key	N		-

Scale

1:1

Perfiles: Aluar-

Multipunto



Sheet No. 1 of 1

Rev. No. E1

KIT OSCIOBATIENTE CON ADAPTADOR PARA MISMA MANIJA MULTIPUNTO en CAMARA EURO

KIT OSCIOBATIENTE MANIJA MULTIPUNTO "NO COPLANAR"

T300A-T	KIT OB T-300 C/GEAR BOX-TITAN 80KG sin brazo
T300A-B	KIT OB T-300 C/GEAR BOX-BLANCO 80KG sin brazo
T300A-N	KIT OB T-300 C/GEAR BOX-NEGRO 80KG sin brazo

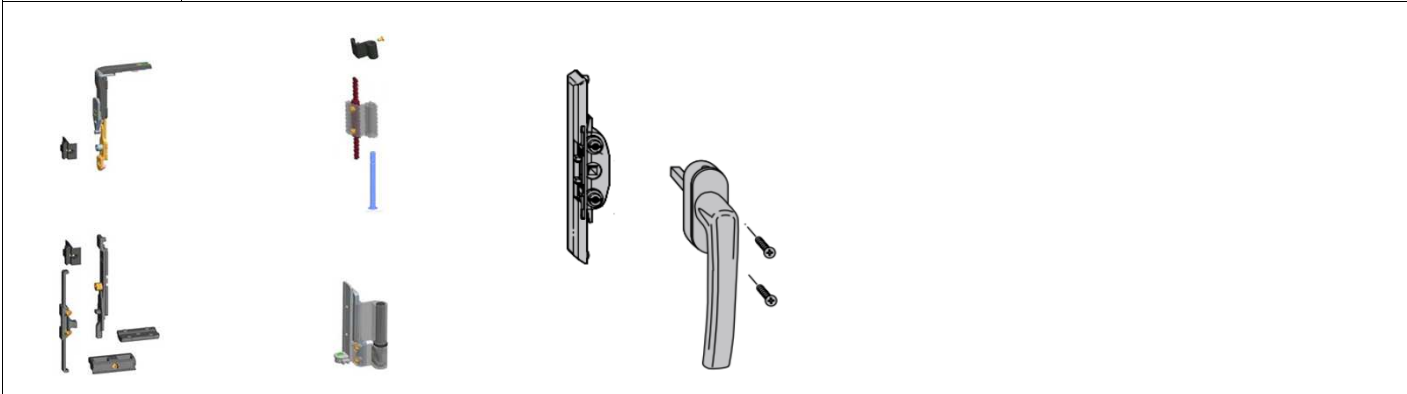

AGREGAR BRAZO OB AL KIT

486457	BRAZO 2 - 700mm ALU T300-6
486458	BRAZO 1 - 390mm ALU T300-6



OPCION CIERRE DE APLICAR PARA OB Y BATIENTE "NO COPLANAR" SOLO BCO Y PLATA

208645	SEG. DE APERTURA BLANCO RAL 9016 R07.2 ALU T300				
377996	SEG. DE APERTURA PLATA R01.5 ALU T300				
212778	PLACA DE CIERRE SEG. APERTURA ALU				

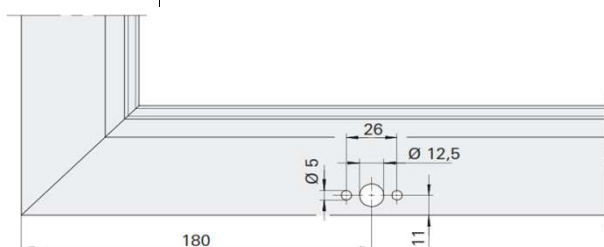
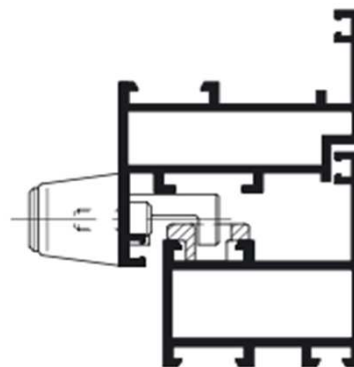

MECANISMO ADAPTADOR INCLUIDO EN EL KIT, que hace posible conectar una manija multipunto a un perfil de camara europea



KIT OSCIOBATIENTE CLASICO CON CREMONA ROTO-LINE ALUMINIO, PERFIL NO COPLANAR

KIT OSCIOBATIENTE CLASICO "NO COPLANAR"

T300-B	KIT T-300 BLANCO 80KG sin brazo
T300-N	KIT T-300 NEGRO 80KG sin brazo
T300-P	KIT T-300 PLATA 80KG sin brazo



AGREGAR BRAZO OB AL KIT

486457	BRAZO 2 - 700mm ALU T300-6
486458	BRAZO 1 - 390mm ALU T300-6



KIT MICROVENTILACION PARA OB

281659

KIT VENTILACION REDUCIDA T-300 MICROVENTILACION 7mm

Permite una apertura con distancia de 7mm para pasaje de aire, llevando la manija OB estandar a 45° desde la posición abatible.

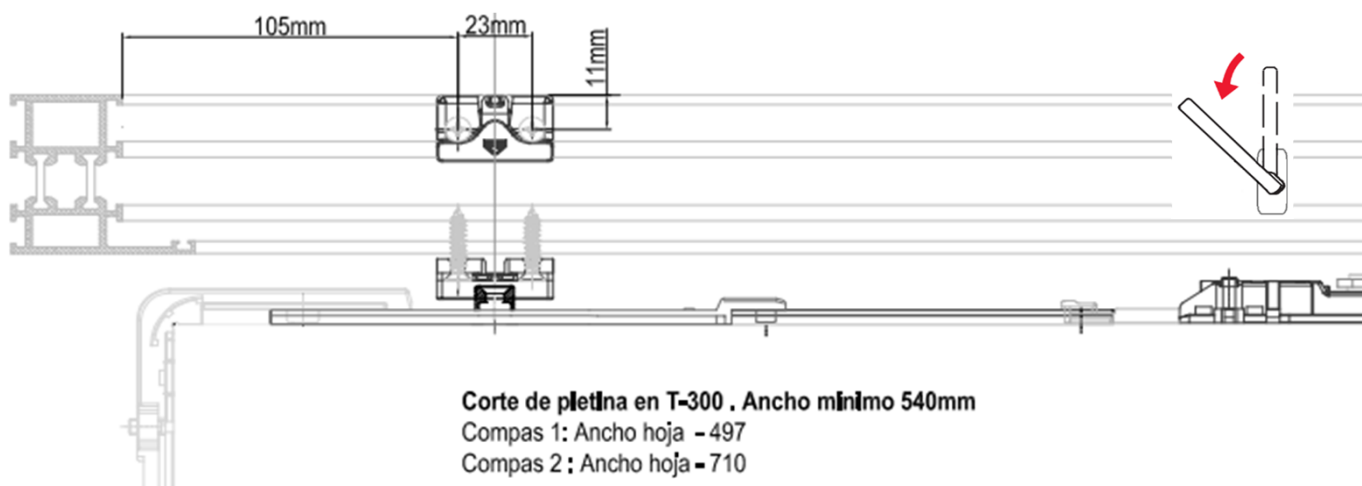

KIT PUERTA BASICO

KIT PUERTA SEGÚN COLOR PARA ANCHO PERFIL 35

PTA1-B	KIT1 PTA AL BLA/ CIL 31 x 31
PTA1-N	KIT1 PTA AL NEGRO/ CIL 31 x 31
PTA1-P	KIT1 PTA AL PLATA/ CIL 31 x 31

KIT PUERTA SEGÚN COLOR PARA ANCHO PERFIL 50, Modena

PTA2-B	KIT2 PTA AL BLA/ CIL 31 x 45
PTA2-N	KIT2 PTA AL NEGRO/ CIL 31 x 45
PTA2-P	KIT2 PTA AL PLAT/ CIL 31 x 45

PUERTA MODENA 6214

451242

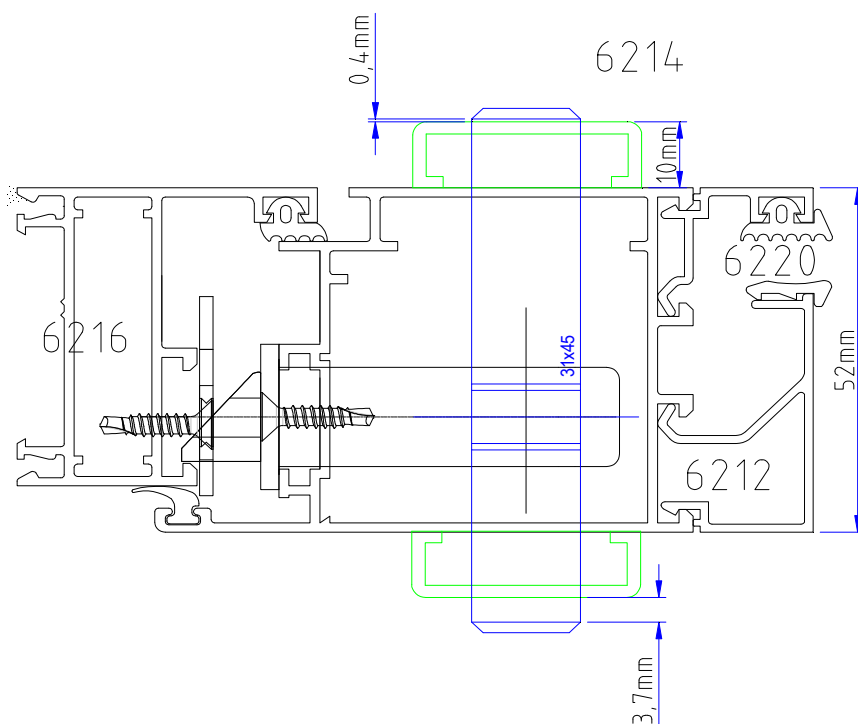

KIT PUERTA SEGÚN COLOR PARA ANCHO PERFIL 60mm, A30 New

PTA3-B	KIT3 PTA AL BLA/ CIL 31 x 55
PTA3-N	KIT3 PTA AL NEGRO/ CIL 31 x 55
PTA3-P	KIT3 PTA AL PLATA/CIL 31 x 55

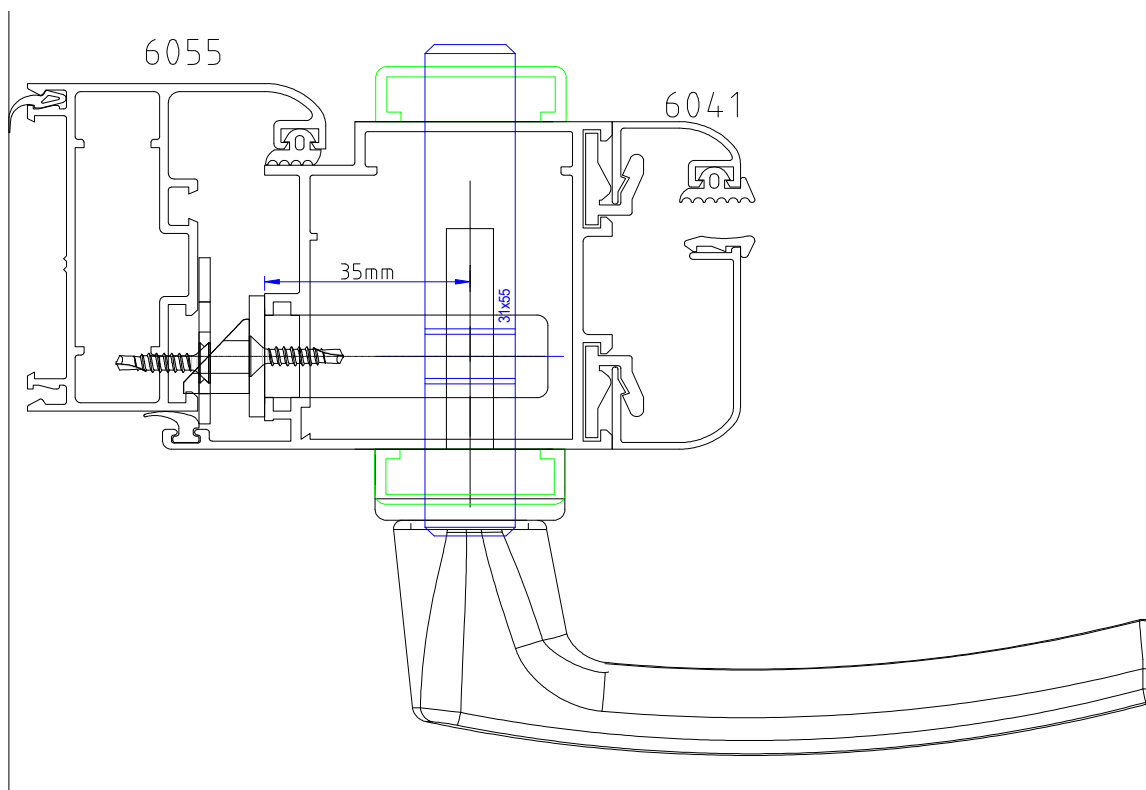

VISTA DEL KIT



CARACTERISTICAS del KIT PUERTA ROTO FRANK:

RESORTE ADICIONAL EN MANIJA: Alarga la vida util del sistema. Dos resortes garantizan que la manivela no caera por el uso extremo y paso del tiempo

TORNILLO PASANTE: Uno de los tornillos de anclaje es pasante y se hermana con una tuerca exterior haciendo la fijacion mas robusta y evitando la caida de la manija con el uso, debido a que no se utiliza solo parker

TUERCA DE SEGURIDAD EXTERIOR: La tuerca exterior de fijacion de manija es hexagonal y ciega, y calza en un alojamiento hexagonal que impedira su giro desde el exterior, evitando la posibilidad de sustraccion de la manija

ROSETA METALICA: La roseta metalica otorga inmejorable estetica. La misma se fija con el cilindro puesto y luego es necesario colocar el recubrimiento antirrobo que oculta los tornillos evitando la sustraccion.

CILINDRO ROTO FRANK: Todos los cilindros de nuestra marca tienen pernos antitaladro en el borde exterior que queda resguardado por la roseta, haciendo imposible su apertura mediante taladrado de resortes.

VISTA DEL TORNILLO PASANTE Y TUERCA EXTERIOR EN SU ALOJAMIENTO HEXAGONAL:

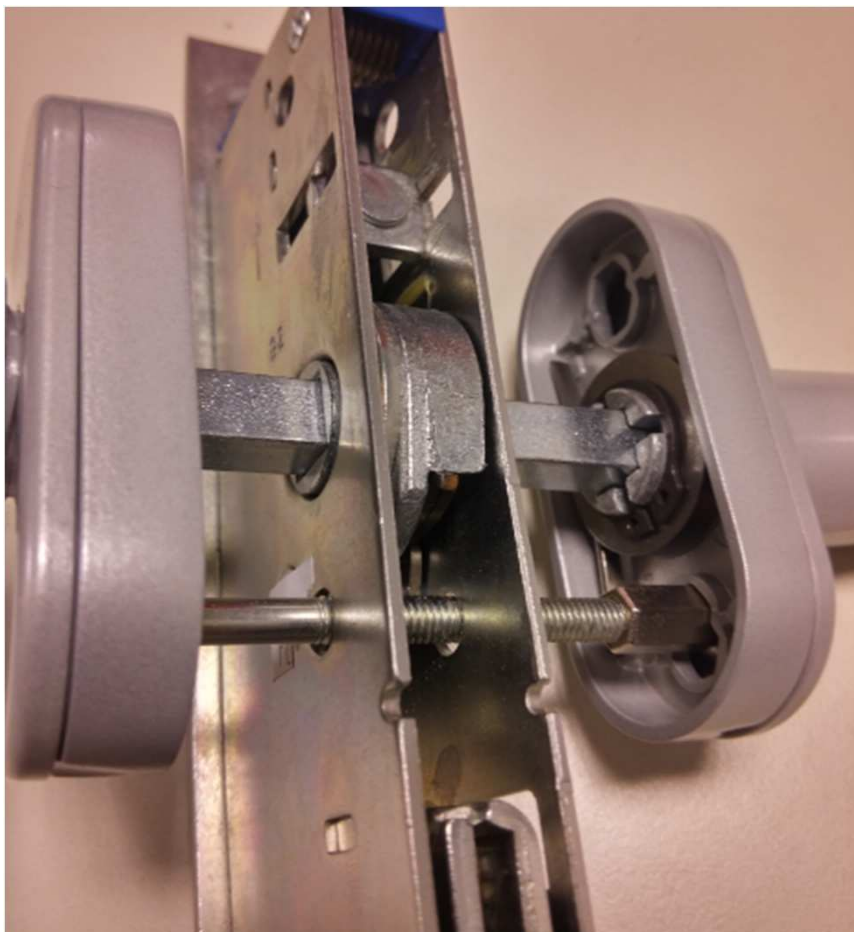

CILINDRO ROTO FRANK CON PERNOS DE ACERO ANTITALADRO, EN TODOS LOS CASOS



CILINDROS SEGÚN PERFIL, LLAVE VIRGEN ROTO FRANK

640068	CILINDRO S6 VERNIKEL 31X31 (62mm)
640069	CILINDRO S6 VERNIKEL 31X45 (76mm)
640070	CILINDRO S6 VERNIKEL 31X50 (81mm)
642659	CILINDRO S6 VERNIKEL 31X55 (86mm)
640080	CILINDRO S6 VERNIKEL 31X60 (91mm)
349755	LLAVE VIRGEN P/CIL ROTO_FRANK

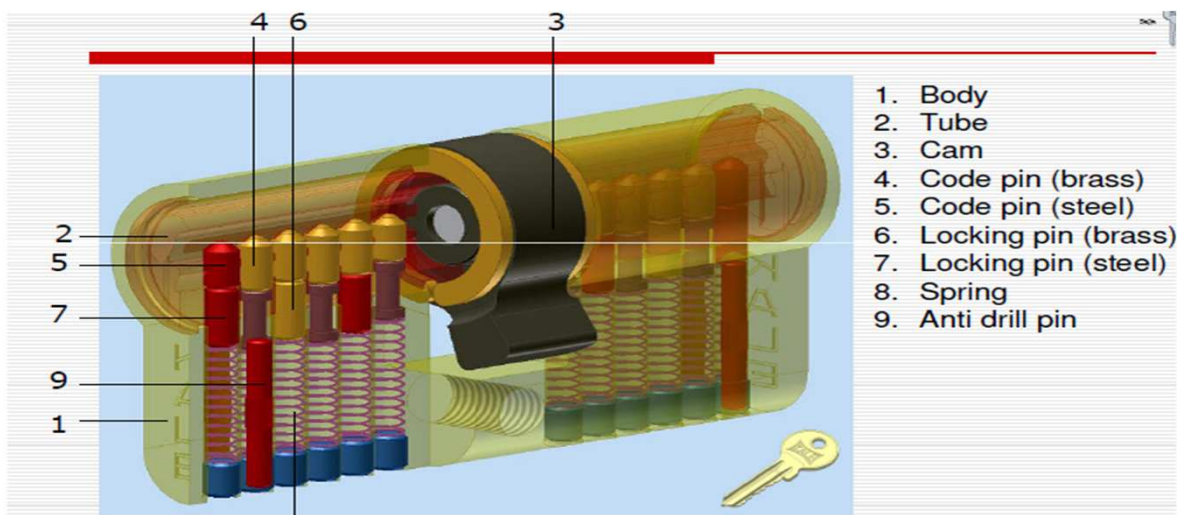

CERRADURA CON PLETINA PARA ENCOLIZAR, EXTENSIBLE CON ANGULOS DE REENVIO

(Necesario utilizar pletina de encolizar 756052GR)

738424	CERRADURA 35/92/8 378mm ALU PLETINA	1
640885	TERMINAL PLASTICA CERRADURA 738424 ALU	2
331012	ANGULO DE REENVIO PARA PUERTA (UNIDAD)	3
490182	CERRADERO VAR. 01 T300	5
334671	BULON DE CIERRE ALU 400i con base	4
611028	CERRADERO CENTRAL IZQ - CAM.EURO	7
611029	CERRADERO CENTRAL DER- CAM.EURO	7

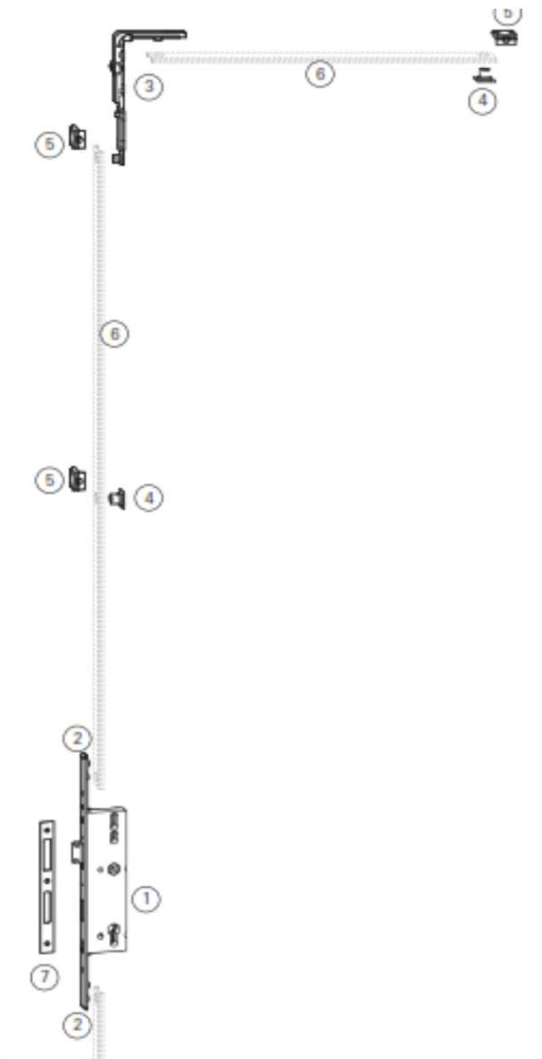



Roto Safe H AL

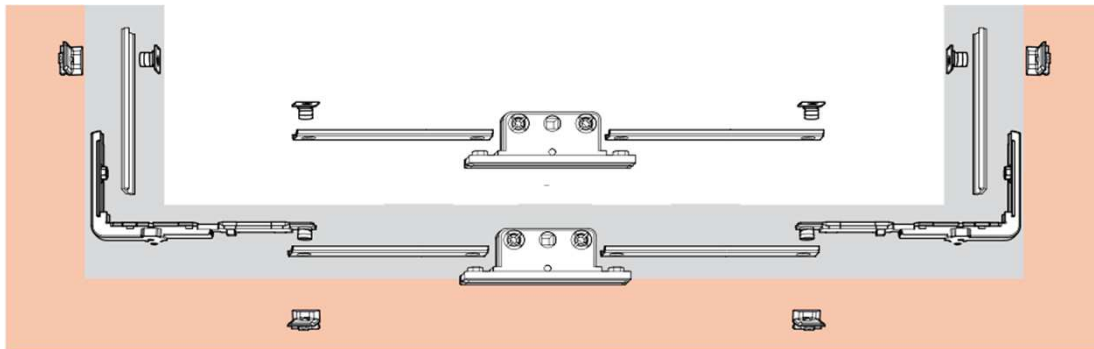

PROYECTANTE A30 CON GEAR BOX

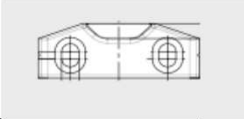
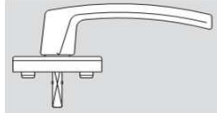

CODIGO	DESCRIPCION	
487489	ADAPT CREMONA AGUJA 25MM. ALUMINIO S.ACC.	
334671	BULON DE CIERRE ALU 400i con base	
212761	CERRADERO PLANO DESPLAZABLE	
490546	MANILLA ROTO-LINE c/tor NEG 30c/Log	
490545	MANILLA ROTO-LINE c/tor BCO 30c/Log	
339532	MANILLA ROTO-LINE c/tor TITAN 30c/Log	
331012	ANGULO DE REENVIO (UNIDAD)	
756052GR	PLETINA DE POLIAMIDA ALU X 1 METROS	
XXXXXXX	SUPLMENTO 10 X 18 NO PROVISTO POR ROTO	

DESPLAZABLE A30 NEW CAJA DE MECANISMO - GEAR BOX

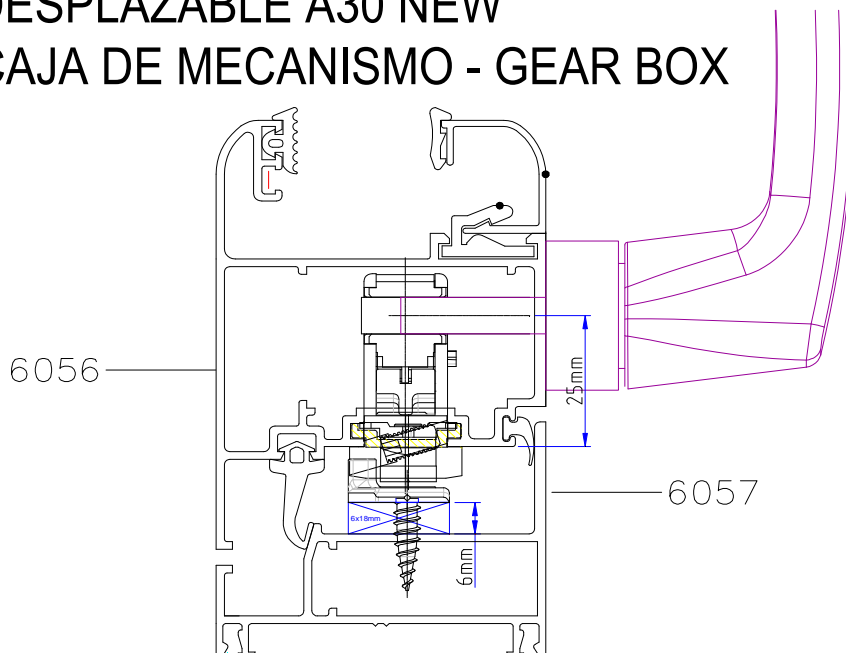

KIT PROYECTANTE ROTO FRANK PIEL DE VIDRIO 6152/6952

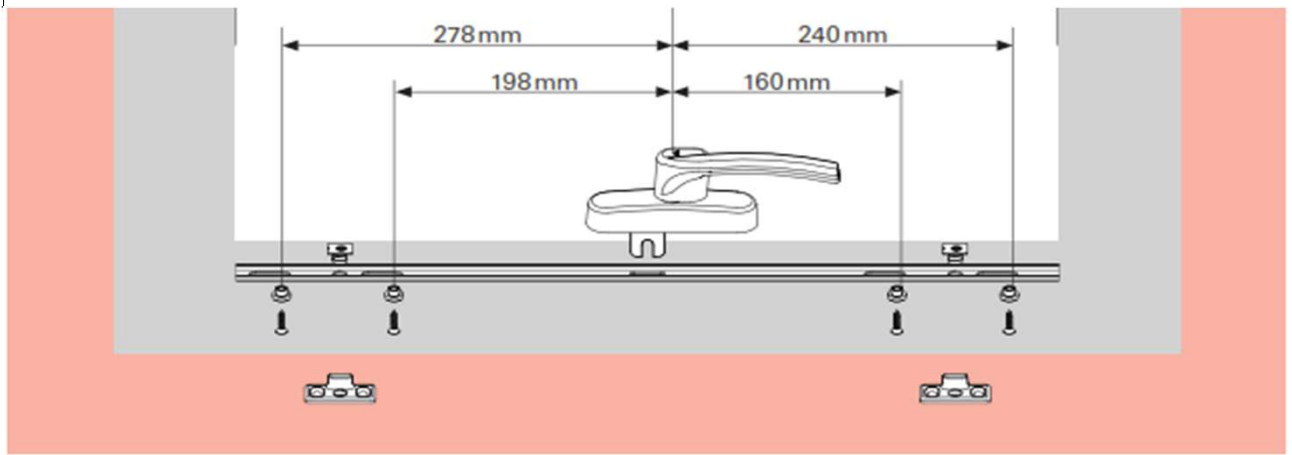
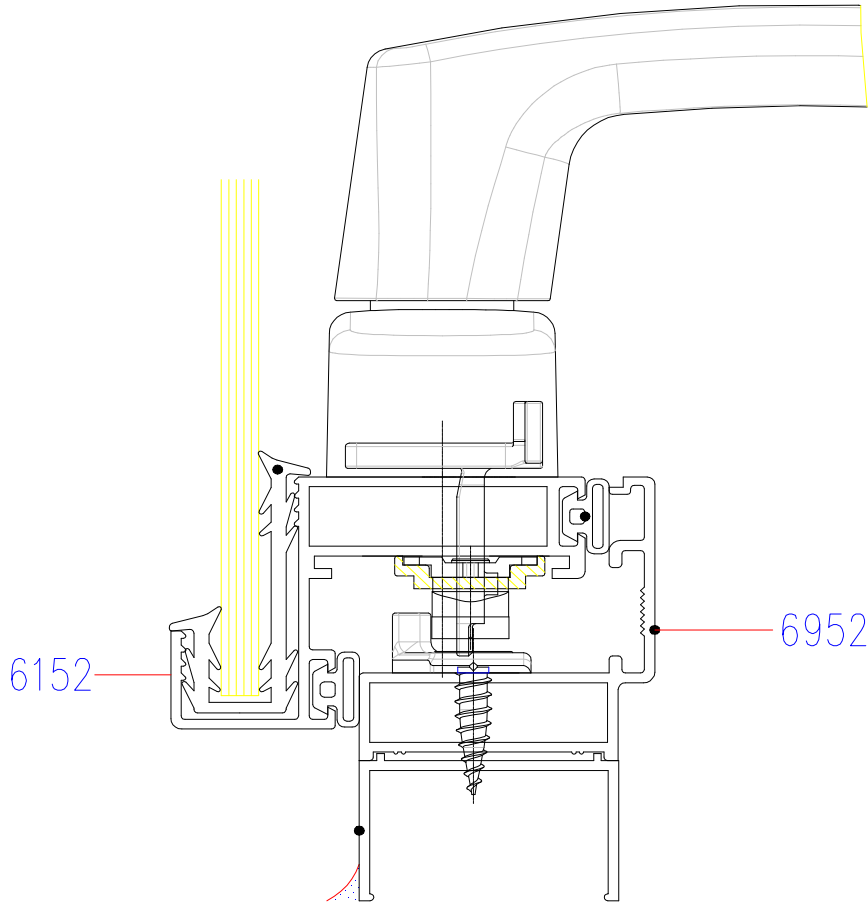

PROHIBIDA LA REPRODUCCION, COPIADO O UTILIZACION DE ESTE DISEÑO SIN EL CONSENTIMIENTO ESCRITO DE ROTO FRANK S.A. SIN PERMISO. Queda prohibida la explotación de este diseño sin el consentimiento escrito de Roto Frank S.A. Sin perjuicio de las acciones legales que correspondan. Queda prohibida la explotación de este diseño sin el consentimiento escrito de Roto Frank S.A. Sin perjuicio de las acciones legales que correspondan.

E18/main / Entwicklung

Qty.	Date	Name	Revision
1			
Issue No.		Replaces	
Effect Key	N		

Scale

1:2

Perfiles: Aluar-

ROTO FRANK S.A.

Multipunto proyectante



Sheet No. 1 of 1

Rev. No. E1

ENSAYO MULTIPUNTO EN A30 PERFIL DE CORTE 90°

El montaje de Multipunto en perfiles de corte a 90° no está avalado por Roto Frank, si bien es perfectamente funcional, según muestran los gráficos. Esto es debido a que al momento de fijar el mecanismo, se debe mecanizar el fondo del perfil a lo largo del mecanismo, debilitando la hoja o limitando la abertura a mecanismos de menores dimensiones, a efectos de mecanizados más cortos que no debiliten la hoja.

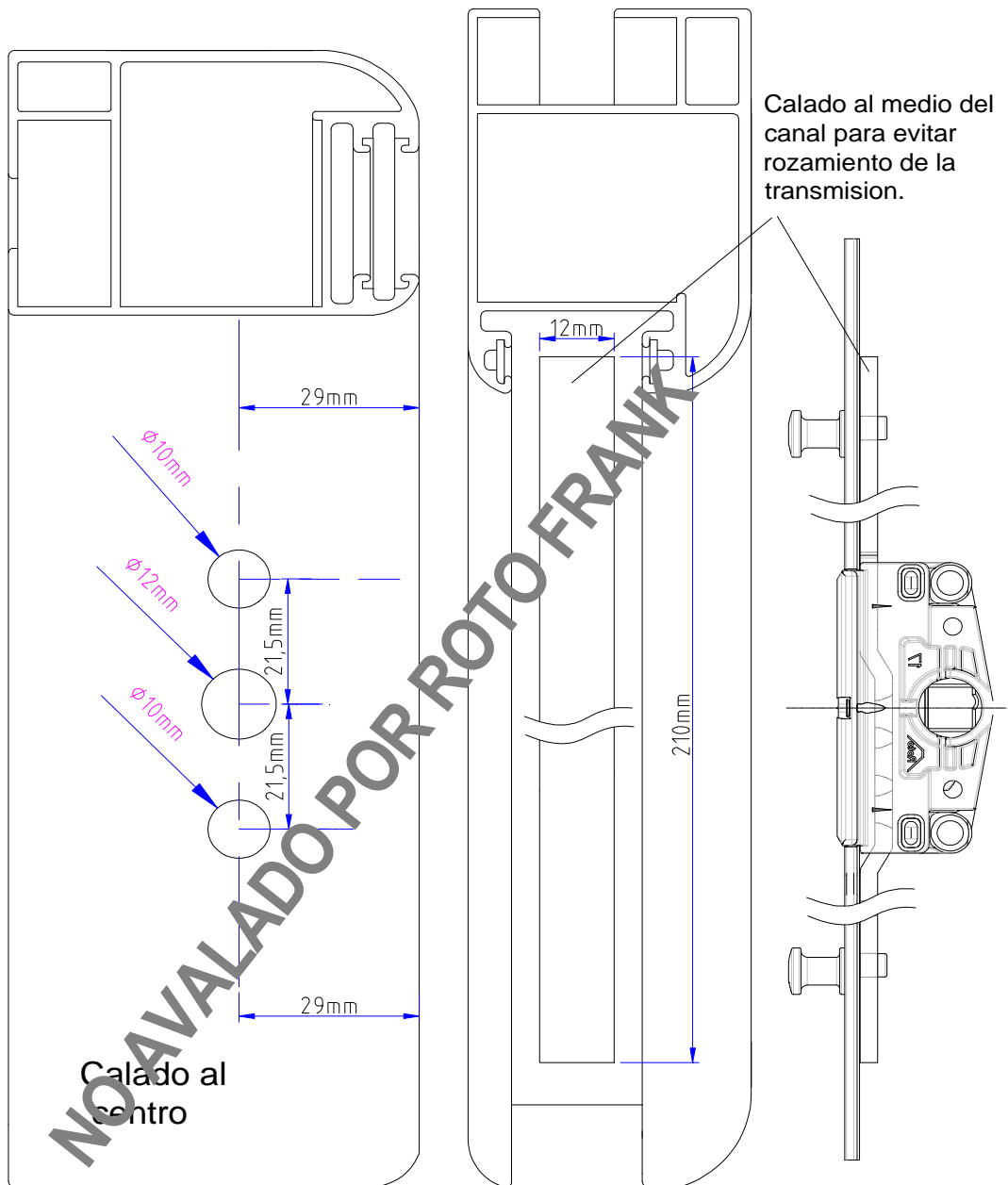

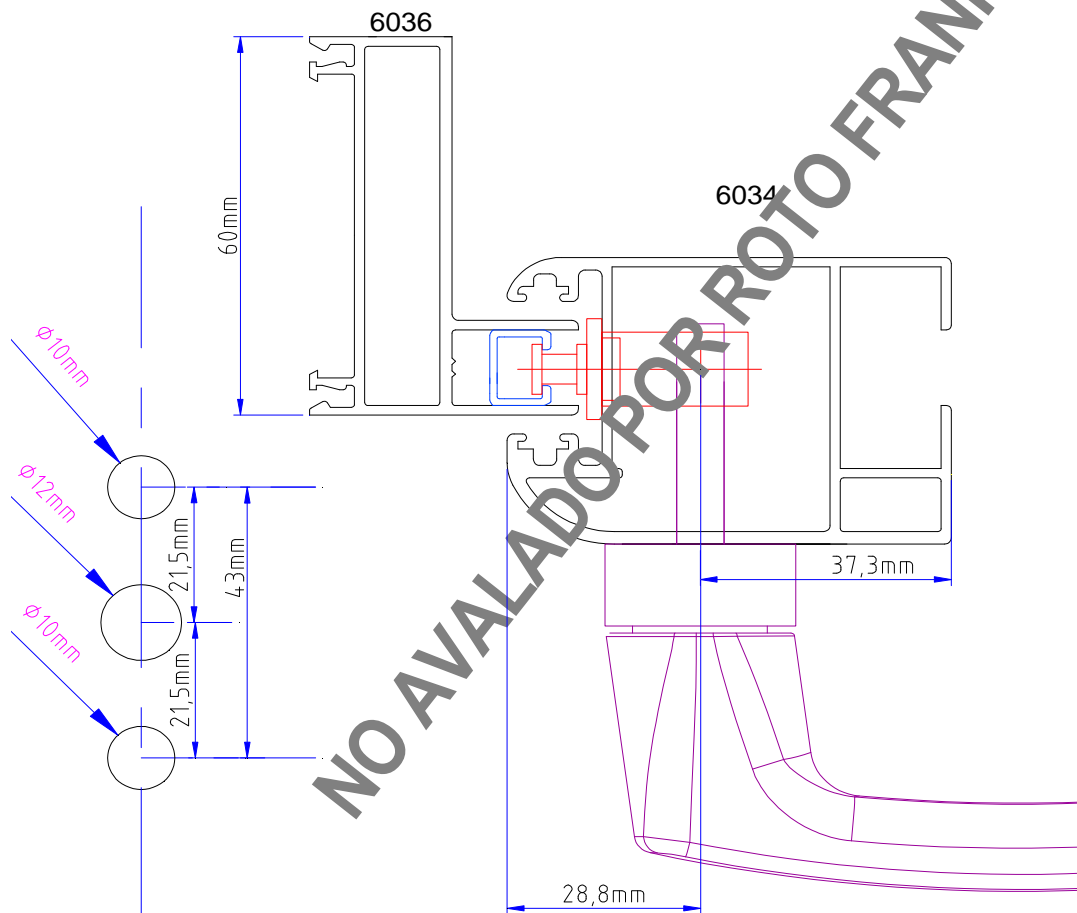

Nota:

Modo de instalacion debe calar el fondo del perfil para permitir el movimiento de la transmision. No avalado por Roto Frank. Cerradero estampado no disponible en Roto Frank

VENTANA Y PUERTA CORREDIZA A30 NEW

Instalacion de Uñero POP-UP

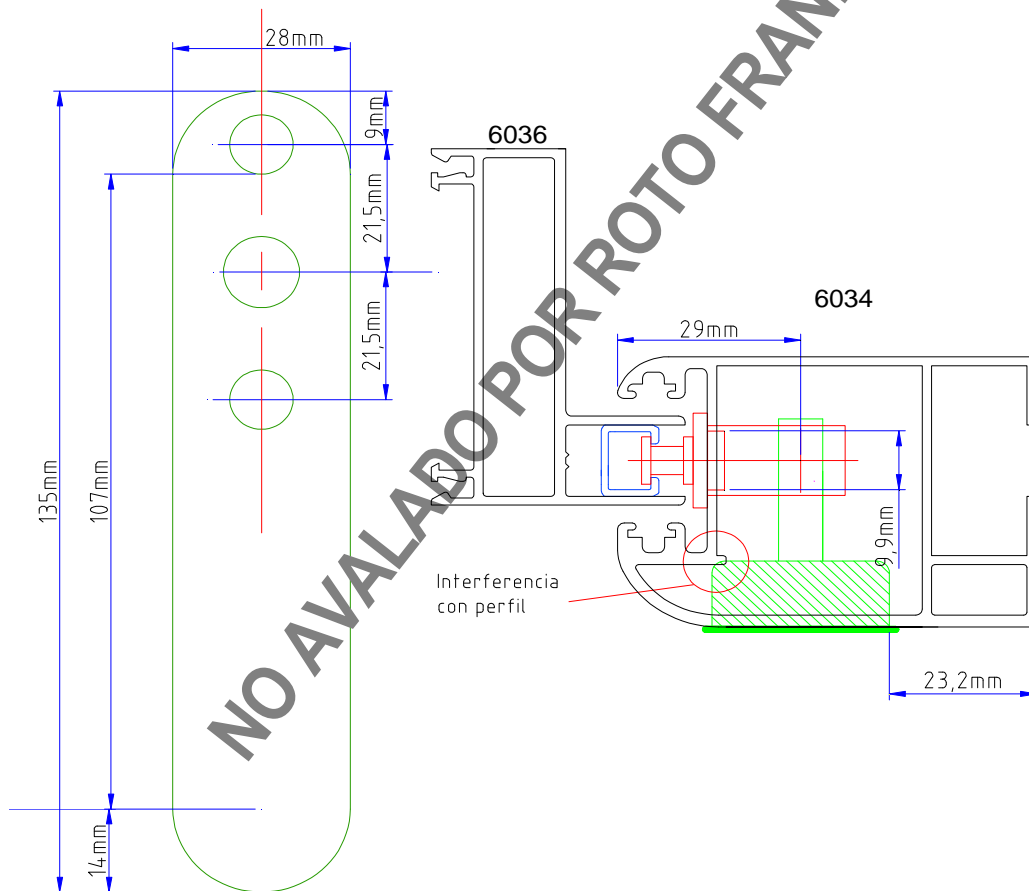

Nota:

Modo de instalacion debe calar el fondo del perfil para permitir el movimiento de la transmision. No avalado por Roto Frank.

GRUPOM22

ALUMINIOS & HERRAJES

Acopio LA PAMPA

Parque Industrial - Santa Rosa
aluminiosg13@grupom22.com.ar

Acopio LINCOLN

Ruta 50 y Av. Salta
Lincoln - BA
lincoln@grupom22.com.ar

Acopio MENDOZA

Av. Ballofet 2731
San Rafael
mendoza@grupom22.com.ar

Acopio PATAGONIA

Parque Industrial
Villa Regina
aluminiospatagon@grupom22.com.ar

Acopio SAN LUIS

San Juan 235 - Villa Mercedes
sanluis@grupom22.com.ar

www.grupom22.com.ar

